



# Dell Precision™ Mobile Workstation M4400 Service Manual

<a href="#">Troubleshooting</a>	<a href="#">LED Cover</a>
<a href="#">Before Working on Your Computer</a>	<a href="#">Keyboard</a>
<a href="#">Base Assembly</a>	<a href="#">Right Speaker Grill and Fingerprint Reader</a>
<a href="#">Hinge Covers</a>	<a href="#">Flash Cache Module</a>
<a href="#">Hard Drive</a>	<a href="#">Palm Rest Assembly</a>
<a href="#">WLAN Card</a>	<a href="#">SD Card Reader</a>
<a href="#">WWAN Card</a>	<a href="#">Express Card Cage</a>
<a href="#">WPAN/UWB Card</a>	<a href="#">System Board Assembly</a>
<a href="#">Fan</a>	<a href="#">Modem</a>
<a href="#">Heat Sinks</a>	<a href="#">I/O Board</a>
<a href="#">Processor Module</a>	<a href="#">DC Power Cable</a>
<a href="#">Memory</a>	<a href="#">Display Assembly</a>
<a href="#">Coin-Cell Battery</a>	<a href="#">Flashing the BIOS</a>
<a href="#">Modular Drive</a>	

Model PP30L

---

## Notes, Notices, and Cautions

-  **NOTE:** A NOTE indicates important information that helps you make better use of your computer.
-  **NOTICE:** A NOTICE indicates either potential damage to hardware or loss of data and tells you how to avoid the problem.
-  **CAUTION:** A CAUTION indicates potential for property damage, personal injury, or death.

If you purchased a DELL™ n Series computer, any references in this document to Microsoft® Windows® operating systems are not applicable.

---

Information in this document is subject to change without notice.  
© 2008 Dell Inc. All rights reserved.

Reproduction in any manner whatsoever without the written permission of Dell Inc. is strictly forbidden.

Trademarks used in this text: *Dell*, the *DELL* logo, and *Dell Precision* are trademarks of Dell Inc.; *Microsoft*, *Windows*, *Windows Vista*, and the *Windows Start button* logo are either trademarks or registered trademarks of Microsoft Corporation in the United States and/or other countries.

Other trademarks and trade names may be used in this document to refer to either the entities claiming the marks and names or their products. Dell Inc. disclaims any proprietary interest in trademarks and trade names other than its own.

August 2008 Rev. A00

[Back to Contents Page](#)

## Base Assembly

Dell Precision™ Service Manual

- [Removing the Bottom of the Base Assembly](#)
- [Replacing the Bottom of the Base Assembly](#)
- [Removing the Base Assembly](#)
- [Replacing the Base Assembly](#)

**⚠ CAUTION:** Before you begin any of the procedures in this section, follow the safety instructions that shipped with your computer.

---

### Removing the Bottom of the Base Assembly

1. Follow the procedures in [Before Working on Your Computer](#).
2. Close the display and turn the computer over.
3. Loosen the M2.5 x 5-mm captive screw.
4. Using the rubber feet for leverage, slide the bottom of the base assembly toward the front of the computer 1/8<sup>th</sup> inch, then lift to remove it.



1	M2.5 x 5-mm captive screw	2	rubber feet
3	bottom of the base assembly		

### Replacing the Bottom of the Base Assembly

1. Slide the bottom of the base assembly into place.
  2. Replace the M2.5 x 5-mm captive screw.
  3. Follow the procedure [After Working on Your Computer](#).
- 

### Removing the Base Assembly

1. Follow the procedures in [Before Working on Your Computer](#).
2. Remove the battery (see [Removing the Battery](#)).
3. Remove the hard drive (see [Removing the Hard Drive](#)).
4. Remove the modular drive (see [Removing the Modular Drive](#)).
5. Remove the bottom of the base assembly (see [Removing the Bottom of the Base Assembly](#)).
6. Remove the modem (see [Removing the Modem](#)).

7. Remove the display assembly (see [Removing the Display Assembly](#)).
8. Remove the keyboard (see [Removing the Keyboard](#)).
9. Remove the card in the WWAN/FCM slot, if present (see [Removing a WWAN Card](#)).
10. Remove the card in the WLAN/WiMax slot, if present (see [Removing a WLAN Card](#)).
11. Remove the card in the WPAN/UWB/FCM slot, if present (see [Removing a WPAN/UWB Card](#)).
12. Remove the memory modules (see [Removing a Memory Module](#)).
13. Remove the fan (see [Removing the Fan](#)).
14. Remove the processor heat sink (see [Removing the Processor Heat Sink](#)).

**NOTICE:** In this procedure, do not detach the processor from the system board.

15. Remove the discrete graphics heat sink (see [Removing the Discrete Graphics Heat Sink](#)).
16. Remove the coin-cell battery (see [Removing the Coin-Cell Battery](#)).
17. Disconnect the DC power cable from the system board. The DC power connector is the seven-wire connector located near the processor.
18. Remove the palm rest assembly (see [Removing the Palm Rest Assembly](#)).
19. Remove the SD card reader assembly (see [Removing the SD Card Reader](#)).
20. Remove the Express card cage assembly (see [Removing the Express Card Cage](#)).
21. Disconnect the orange I/O board cable from the system board.
22. Remove the two M2 x 3-mm screws securing the PC card cage.
23. Uncouple the PC card cage from its mounting bracket by lifting the latch tab with a small plastic scribe.

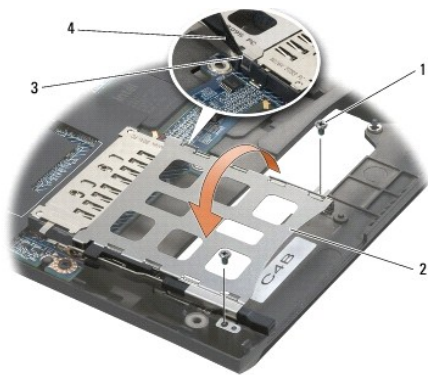

1	M2 x 3-mm screw (2)	2	PC card cage
3	latch tab	4	plastic scribe

24. Remove the five M2.5 x 5-mm screws labeled with white arrows from the system board.
25. Pull out on the top, left corner of the base assembly to release the DC, USB, and display connectors.
26. Remove the system board (see [Removing the System Board Assembly](#)).
27. Remove the I/O board (see [Removing the I/O Board](#)).
28. Remove the DC power cable from the base.
29. Remove the modem cable from the base.

---

## Replacing the Base Assembly

The base assembly has no electronic components installed. It does include the battery latches.

1. Install the DC power cable into the base assembly. Place the external power cable connector into its mounting slot, then Route the cable through its cabling channel.
2. Install the modem cable. Place the external modem cable connector into its mounting slot, then route the cable through its cabling channel.
3. Replace the I/O board (see [Replacing the I/O Board](#)).
4. Replace the system board (see [Replacing the System Board Assembly](#)).
5. Replace the card cage (see [Replacing the Express Card Cage](#)).
6. Replace the SD card reader assembly (see [Replacing the SD Card Reader](#)).
7. Replace the PC card cage. Secure the PC card cage with two M2 x 3-mm screws.
8. Replace the palm rest assembly and thermal plate (see [Replacing the Palm Rest Assembly](#)).
9. Replace the keyboard and LED cover (see [Replacing the Keyboard](#)).
10. Replace the display assembly (see [Replacing the Display Assembly](#)).
11. Reconnect the DC power cable to the system board.
12. Replace the coin-cell battery (see [Replacing the Coin-Cell Battery](#)).
13. Replace the discrete graphics heat sink (see [Replacing the Discrete Graphics Heat Sink](#)).
14. Replace the processor heat sink (see [Replacing the Processor Heat Sink](#)).
15. Replace the fan (see [Replacing the Fan](#)).
16. Replace the memory module(s) (see [Replacing a Memory Module](#)).
17. Replace the card in the WWAN/FCM slot, if it was present (see [Replacing a WWAN Card](#)).
18. Replace the card in the WLAN/WiMax slot, if it was present (see [Replacing a WLAN Card](#)).
19. Replace the card in the WPAN/UWB/FCM slot, if it was present (see [Replacing a WPAN/UWB Card](#)).
20. Replace the modem (see [Replacing the Modem](#)).
21. Replace the bottom of the base assembly (see [Replacing the Bottom of the Base Assembly](#)).
22. Replace the modular drive (see [Replacing the Modular Drive](#)).
23. Replace the hard drive (see [Replacing the Hard Drive](#)).
24. Replace the battery (see [Replacing the Battery](#)).
25. Follow the procedure [After Working on Your Computer](#).

---

[Back to Contents Page](#)

[Back to Contents Page](#)

## Before Working on Your Computer

Dell Precision™ Service Manual

- [Recommended Tools](#)
- [What You Need to Know for Your Safety](#)
- [Removing the Battery](#)
- [Replacing the Battery](#)
- [After Working on Your Computer](#)

This document provides procedures for removing and installing the components in your computer. Unless otherwise noted, each procedure assumes that:

- 1 You have performed the steps in [Before Working on Your Computer](#).
- 1 You have read the safety information that shipped with your computer.
- 1 When replacing a component, you have already removed the original, if installed.

 **NOTE:** The color of your system and certain system components may appear differently than shown in this document.

---





## Recommended Tools



The procedures in this document may require the following tools:

- 1 Small flat-blade screwdriver
  - 1 Phillips #0 screwdriver
  - 1 Small plastic scribe
  - 1 Flash BIOS update (see the Dell Support website at [support.dell.com](http://support.dell.com))
- 

## What You Need to Know for Your Safety

Use the following safety guidelines to help protect your computer from potential damage and to help ensure your own personal safety.

-  **CAUTION:** Before working inside your computer, read the safety information that shipped with your computer. For additional safety best practices information, see the Regulatory Compliance Homepage on [www.dell.com](http://www.dell.com) at: [www.dell.com/regulatory\\_compliance](http://www.dell.com/regulatory_compliance).
-  **NOTICE:** Only a certified service technician should perform repairs on your computer. Damage due to servicing that is not authorized by Dell is not covered by your warranty.
-  **NOTICE:** To avoid electrostatic discharge, ground yourself by using a wrist grounding strap or by periodically touching an unpainted metal surface, such as a connector on the back of the computer.
-  **NOTICE:** Handle components and cards with care. Do not touch the components or contacts on a card. Hold a card by its edges or by its metal mounting bracket. Hold a component such as a processor by its edges, not by its pins.
-  **NOTICE:** When disconnecting a cable, pull on the cable's connector or on its strain-relief loop, not on the cable itself. For cable connectors with locking tabs, press inward on the locking tabs to release the connector. When connecting a cable, ensure that the connectors are correctly oriented and aligned to avoid damage to the connector and/or the connector's pins.

1. Ensure that the work surface is flat and clean to prevent the computer cover from being scratched.
2. Shut down your computer.
  - 1 In Windows® XP, click **Start**→ **Shutdown**→ **Shutdown**.
  - 1 In Windows Vista®, click **Start** , click the arrow  icon, and then click **Shut Down**.

 **NOTE:** Ensure that the computer is off and not in a power management mode. If you cannot shut down the computer using the operating system, press and hold the power button for 4 seconds.

3. Disconnect your computer and all attached devices from their electrical outlets.

 **NOTICE:** To disconnect a network cable, first unplug the cable from your computer, and then unplug it from the network wall jack.

4. Disconnect any telephone or network cables from the computer.
5. Remove any installed cards.

 **NOTICE:** To help prevent damage to the system board, you must remove the battery from the battery bay before you service the computer.

**NOTE:** To avoid damage to the computer, use only the battery designed for this particular Dell computer. Do not use batteries designed for other Dell computers.

6. Turn the computer over.
- 

## Removing the Battery

1. Slide the battery release latches to the open position. (The latches lock into place).
2. Grip the battery and slide it out of the battery bay.

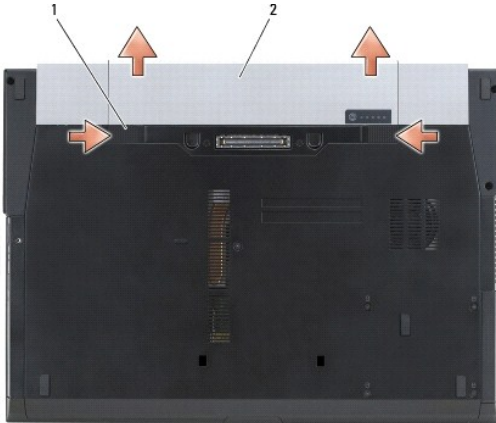

1 battery release latches (2) 2 battery

3. Turn the computer top-side up, open the display, and press the power button to ground the system board.
- 

## Replacing the Battery

1. Slide a battery into the battery bay until it clicks into place.
  2. Turn the computer top-side up, open the display, and press the power button to ground the system board.
- 

## After Working on Your Computer

After you have completed the replacement procedures, ensure you connect the external devices, cards, cables, and so on, before turning on your computer.

**NOTE:** To avoid damage to the computer, use only the battery designed for this particular Dell computer. Do not use batteries designed for other Dell computers.

1. Replace the battery. Slide the battery into the battery bay until it clicks into place.
  2. Connect any external devices, such as a port replicator, battery slice, or cool slice, and replace any cards, such as an ExpressCard.
  3. Connect any telephone or network cables to your computer.
  4. Connect your computer and all attached devices to their electrical outlets.
  5. Turn on your computer.
- 

[Back to Contents Page](#)

## Flashing the BIOS

### Dell Precision™ Service Manual

- [Flashing the BIOS From a CD](#)
- [Flashing the BIOS From the Hard Drive](#)

If a BIOS-update program CD is provided with a new system board, flash the BIOS from the CD. If you do not have a BIOS-update program CD, flash the BIOS from the hard drive.

---

### Flashing the BIOS From a CD

➡ **NOTICE:** Plug the DC adapter into a known good power source to prevent a loss of power. Failure to do so may cause system damage.

1. Ensure that the DC adapter is plugged in and that the main battery is installed properly.
2. Press <F12> before inserting the BIOS-update program CD so that you can set up the computer to boot from a CD for one time only. Otherwise, you must enter the system setup program to change the default boot order.
3. Insert the BIOS-update program CD, and turn on the computer.

➡ **NOTICE:** Do not interrupt this process once it begins. Doing so may cause system damage.

Follow the instructions that appear on the screen. The computer continues to boot and updates the new BIOS. When the flash update is complete, the computer will automatically reboot.

4. Remove the flash BIOS update program CD from the drive.
- 

### Flashing the BIOS From the Hard Drive

➡ **NOTICE:** Plug the DC adapter into a known good power source to prevent a loss of power. Failure to do so may cause system damage.

1. Ensure that the DC adapter is plugged in, the main battery is properly installed, and a network cable is attached.
2. Turn on the computer.
3. Locate the latest BIOS update file for your computer at [support.dell.com](http://support.dell.com).
4. Click **Download Now** to download the file.
5. If the **Export Compliance Disclaimer** window appears, click **Yes, I Accept this Agreement**.

The **File Download** window appears.

6. Click **Save this program to disk**, and then click **OK**.

The **Save In** window appears.

7. Click the down arrow to view the **Save In** menu, select **Desktop**, and then click **Save**.

The file downloads to your desktop.

8. Click **Close** if the **Download Complete** window appears.

The file icon appears on your desktop and is titled the same as the downloaded BIOS update file.

9. Double-click the file icon on the desktop and follow the instructions on the screen.
-

## Express Card Cage

### Dell Precision™ Service Manual

- [Removing the Express Card Cage](#)
- [Replacing the Express Card Cage](#)

---

## Removing the Express Card Cage

**⚠ CAUTION:** Before you begin any of the procedures in this section, follow the safety instructions that shipped with your computer.

1. Follow the procedures in [Before Working on Your Computer](#).
2. Remove the hard drive (see [Removing the Hard Drive](#)).
3. Remove the modular drive (see [Removing the Modular Drive](#)).
4. Remove the bottom of the base assembly (see [Removing the Bottom of the Base Assembly](#)).
5. Remove the display assembly (see [Removing the Display Assembly](#)).
6. Remove the keyboard (see [Removing the Keyboard](#)).
7. Remove the palm rest assembly ([Removing the Palm Rest Assembly](#)).
8. If a card is in the cage, remove the card.
9. Remove the three M2 x 3-mm screws that secure the Express card cage to the base assembly.
10. Disconnect the Express card cable from the system board.
11. Lift the Express card cage away from the system board.



1	Express card carrier	2	M2 x 3-mm screw (3)
3	Express card cable connector		

---

## Replacing the Express Card Cage

**⚠ CAUTION:** Before you begin any of the procedures in this section, follow the safety instructions that shipped with your computer.

1. Attach one side of the carrier and then the other and set it in place.
2. Replace the three M2 x 3-mm screws to secure the Express card cage to the base assembly.



3. Reconnect the Express card cable to the system board.
  4. Replace the palm rest assembly ([Replacing the Palm Rest Assembly](#)).
  5. Replace the keyboard (see [Replacing the Keyboard](#)).
  6. Replace the display assembly (see [Replacing the Display Assembly](#)).
  7. Replace the bottom of the base assembly (see [Replacing the Bottom of the Base Assembly](#)).
  8. Replace the modular drive (see [Replacing the Modular Drive](#)).
  9. Replace the hard drive (see [Replacing the Hard Drive](#)).
  10. Follow the procedure [After Working on Your Computer](#).
- 

[Back to Contents Page](#)

## Coin-Cell Battery

### Dell Precision™ Service Manual

- [Removing the Coin-Cell Battery](#)
- [Replacing the Coin-Cell Battery](#)

---

## Removing the Coin-Cell Battery

- ⚠ **CAUTION:** Before you begin any of the procedures in this section, follow the safety instructions that shipped with your computer.
- 🔄 **NOTICE:** Disconnecting the coin-cell battery from the system board with no other power source causes the BIOS to reset to the default configuration and sets the realtime clock to the build date. System configuration changes made in the BIOS by the user must be re-entered, and the system clock must be set.

1. Follow the procedures in [Before Working on Your Computer](#).
2. Remove the bottom of the base assembly (see [Removing the Bottom of the Base Assembly](#)).
3. Pry up the coin-cell battery to release the double-sided adhesive tape on the bottom.
4. Lift the coin-cell battery out of the computer.
5. Disconnect the coin-cell battery cable from the system board.

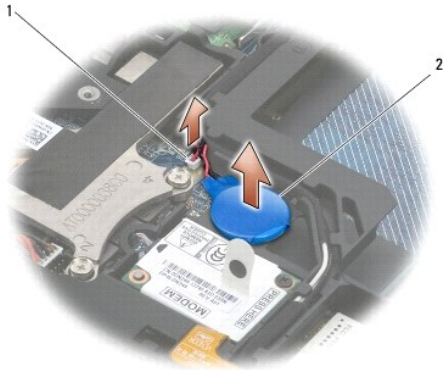

1	battery cable connector	2	coin-cell battery
---	-------------------------	---	-------------------

---

## Replacing the Coin-Cell Battery

- ⚠ **CAUTION:** Before you begin any of the procedures in this section, follow the safety instructions that shipped with your computer.

1. Connect the coin-cell battery cable to the system board.
2. Insert the coin-cell battery into the computer.
3. If you are re-installing the old coin-cell battery, press down to secure the tape to the base assembly.
4. Replace the bottom of the base assembly (see [Replacing the Bottom of the Base Assembly](#)).
5. Follow the procedure [After Working on Your Computer](#).



## Processor Module

### Dell Precision™ Service Manual

- [Removing the Processor Module](#)
- [Replacing the Processor Module](#)

## Removing the Processor Module

**⚠ CAUTION:** Before working inside your computer, read the safety information that shipped with your computer. For additional safety best practices information, see the Regulatory Compliance Homepage on [www.dell.com](http://www.dell.com) at: [www.dell.com/regulatory\\_compliance](http://www.dell.com/regulatory_compliance).

1. Follow the instructions in [Before Working on Your Computer](#).
2. Remove the bottom of the base assembly (see [Removing the Bottom of the Base Assembly](#)).
3. Remove the fan (see [Removing the Fan](#)).
4. Remove the processor heat sink (see [Removing the Processor Heat Sink](#)).

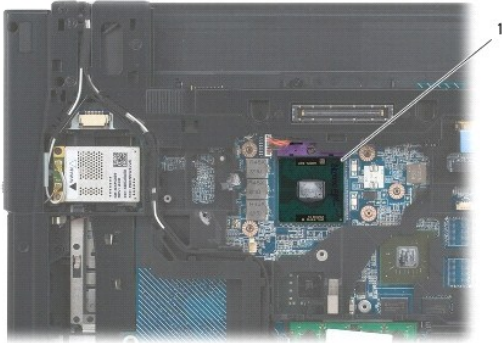

1	processor module (CPU)		
---	------------------------	--	--

➡ **NOTICE:** To avoid damage to the processor, hold the screwdriver so that it is perpendicular to the processor when turning the cam screw.

5. To loosen the ZIF socket, use a small, flat-blade screwdriver and rotate the ZIF-socket cam screw counterclockwise almost 1/3 turn (until it stops).



1	ZIF-socket cam screw	2	ZIF socket
---	----------------------	---	------------





➡ **NOTICE:** To ensure maximum cooling for the processor, do not touch the heat transfer areas on the processor heat sink. The oils in your skin can reduce the heat transfer capability of the thermal pads.

➡ **NOTICE:** When removing the processor module, pull the module straight up. Be careful not to bend the pins on the processor module.

6. Lift the processor module from the ZIF socket.

---

## Replacing the Processor Module

-  **CAUTION:** Before working inside your computer, read the safety information that shipped with your computer. For additional safety best practices information, see the Regulatory Compliance Homepage on [www.dell.com](http://www.dell.com) at: [www.dell.com/regulatory\\_compliance](http://www.dell.com/regulatory_compliance).
-  **NOTICE:** Do not touch the processor die. Press and hold the processor down on the substrate on which the die is mounted while turning the cam screw to prevent intermittent contact between the cam screw and processor.
-  **NOTICE:** Ensure that the cam lock is in the fully open position before seating the processor module. Seating the processor module properly in the ZIF socket does not require force. A processor module that is not properly seated can result in an intermittent connection or permanent damage to the microprocessor and ZIF socket.
-  **NOTE:** If a new processor is installed, you will receive a new heat sink, which will include a thermal pad, or you will receive a new thermal pad along with a tech sheet to illustrate proper installation.

1. Align the pin-1 corner of the processor module with the pin-1 corner of the ZIF socket, then insert the processor module.

 **NOTE:** The pin-1 corner of the processor module has a triangle that aligns with the triangle on the pin-1 corner of the ZIF socket.

When the processor module is properly seated, all four corners are aligned at the same height. If one or more corners of the module are higher than the others, the module is not seated properly. There should be no resistance when inserting the processor module into the ZIF socket.

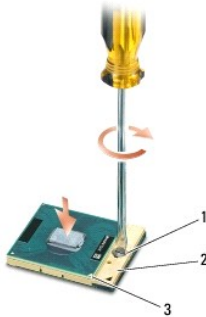

1	ZIF-socket cam screw	2	ZIF socket
3	pin-1 corner		

-  **NOTICE:** To avoid damage to the processor, hold the screwdriver so that it is perpendicular to the processor when turning the cam screw.
2. Tighten the ZIF socket by turning the cam screw clockwise about 1/3 turn (until it stops) to secure the processor module to the system board.
  3. Replace the processor heat sink (see [Replacing the Discrete Graphics Heat Sink](#)).
  4. Replace the fan (see [Replacing the Fan](#)).
  5. Replace the bottom of the base assembly (see [Removing the Bottom of the Base Assembly](#)).
  6. Follow the procedure [After Working on Your Computer](#).

[Back to Contents Page](#)

## Heat Sinks

### Dell Precision™ Service Manual

- [Removing the Processor Heat Sink](#)
- [Removing the Discrete Graphics Heat Sink](#)
- [Replacing the Discrete Graphics Heat Sink](#)
- [Replacing the Processor Heat Sink](#)

**⚠ CAUTION:** Before working inside your computer, read the safety information that shipped with your computer. For additional safety best practices information, see the Regulatory Compliance Homepage on [www.dell.com](http://www.dell.com) at: [www.dell.com/regulatory\\_compliance](http://www.dell.com/regulatory_compliance).

The Dell Precision™ M4400 contains two heat sinks. They are referred to as the processor heat sink and the discrete graphics heat sink.

---

## Removing the Processor Heat Sink

To remove the processor heat sink, complete the following steps:

1. Follow the instructions in [Before Working on Your Computer](#).
2. Close the display and turn the computer over.
3. Remove the bottom of the base assembly (see [Removing the Bottom of the Base Assembly](#)).
4. Remove the fan (see [Removing the Fan](#)).
5. Loosen, in sequential order, the four captive screws that secure the processor heat sink to the system board.
6. Carefully lift the screw-end of the assembly up at an angle, then ease the vent-end of the assembly out of the computer.

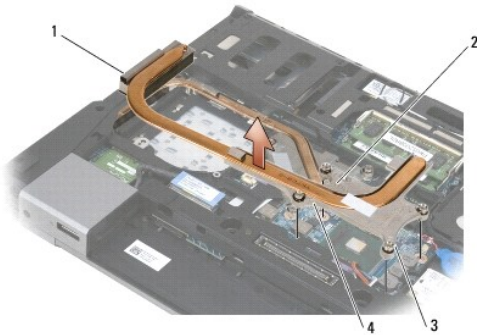

1	vent-end of assembly	2	processor heat sink
3	captive screw (4)	4	screw-end of assembly

---

## Removing the Discrete Graphics Heat Sink

Before removing the discrete graphics heat sink, the processor heat sink must be removed.

1. Loosen the three captive screws that secure the graphics heat sink to the system board.
2. Carefully lift the screw-end of the assembly up at an angle, then ease the vent-end of the assembly out of the computer.

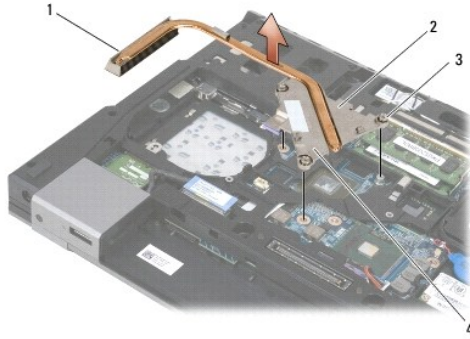

1	vent-end of assembly	2	discrete graphics heat sink
3	captive screws (3)	4	screw-end of assembly

---

## Replacing the Discrete Graphics Heat Sink

**⚠ CAUTION:** Before working inside your computer, read the safety information that shipped with your computer. For additional safety best practices information, see the Regulatory Compliance Homepage on [www.dell.com](http://www.dell.com) at: [www.dell.com/regulatory\\_compliance](http://www.dell.com/regulatory_compliance).

Before installing the discrete graphics heat sink, the processor heat sink must be removed. See [Removing the Processor Heat Sink](#).

1. Apply thermal solution to the surface of the graphics chip as required. Clean excess thermal solution from the conductive pad of the discrete graphics heat sink.
2. Place the vent-end of the discrete graphics heat sink into the computer at an angle, then align the three captive screws on the heat sink with the screw holes on the system board.
3. In sequential order, tighten the three captive screws to secure the heat sink to the system board.

---

## Replacing the Processor Heat Sink

1. Place the vent-end of the processor heat sink into the computer at an angle, then align the four captive screws on the heat sink with the screw holes on the system board.
2. In sequential order, tighten the four captive screws to secure the heat sink to the system board.
3. Replace the fan (see [Replacing the Fan](#)).
4. Replace the bottom of the base assembly (see [Removing the Bottom of the Base Assembly](#)).
5. Follow the procedure [After Working on Your Computer](#).

---

[Back to Contents Page](#)

## I/O Board

### Dell Precision™ Service Manual

- [Removing the I/O Board](#)
- [Replacing the I/O Board](#)

---

## Removing the I/O Board

**⚠ CAUTION:** Before you begin the following procedure, follow the safety instructions that shipped with your computer.

1. Follow the procedures in [Before Working on Your Computer](#).

**🔁 NOTICE:** When removing the system board to access the I/O board, it is not necessary to remove the processor from the system board.

2. Remove the system board (see [Removing the System Board Assembly](#)).
3. Remove the two M2 x 3-mm screws from the I/O board.
4. Lift the I/O board out of the base by first raising the inside (left) edge of the card, then withdrawing the right edge of the card from under the wireless switch actuators.

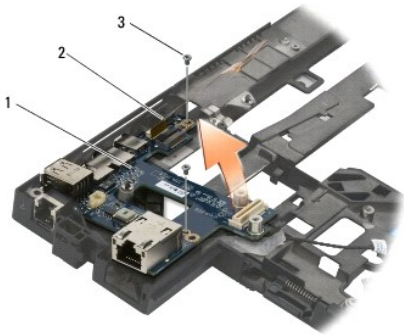

1	I/O board	2	wireless switch actuator
3	M2 x 3-mm screw (2)		

---

## Replacing the I/O Board

**⚠ CAUTION:** Before you begin the following procedure, follow the safety instructions that shipped with your computer.

**🔁 NOTICE:** When installing the I/O board into the base, ensure that the wireless switch actuator mates properly with the switch post on the I/O board.

1. Install the I/O board into the base assembly by first placing the outside (right) edge of the card under the wireless switch actuators, then lowering the left edge of the board onto the locator pins.
  2. Replace the two M2 x 3-mm screws to secure the I/O board to the base assembly.
  3. Slide the wireless switch on and off to ensure that it functions without any obstruction.
  4. Replace the system board (see [Replacing the System Board Assembly](#)).
  5. Follow the procedure [After Working on Your Computer](#).
-



[Back to Contents Page](#)

## Display Assembly

Dell Precision™ Service Manual

<a href="#">● Removing the Display Assembly</a>	<a href="#">● Replacing the Camera and Microphone Assembly</a>
<a href="#">● Replacing the Display Assembly</a>	<a href="#">● Removing the Latch Hook</a>
<a href="#">● Removing the Display Bezel</a>	<a href="#">● Replacing the Latch Hook</a>
<a href="#">● Replacing the Display Bezel</a>	<a href="#">● Removing the Display Bracket</a>
<a href="#">● Removing the Display Panel</a>	<a href="#">● Replacing the Display Bracket</a>
<a href="#">● Replacing the Display Panel</a>	<a href="#">● Remove the Display Cover</a>
<a href="#">● Display Inverter</a>	<a href="#">● Replace the Display Cover</a>
<a href="#">● Removing the Camera and Microphone Assembly</a>	

### Removing the Display Assembly

**CAUTION:** Before working inside your computer, read the safety information that shipped with your computer. For additional safety best practices information, see the Regulatory Compliance Homepage on [www.dell.com](http://www.dell.com) at: [www.dell.com/regulatory\\_compliance](http://www.dell.com/regulatory_compliance).

**NOTICE:** Position all display assembly cables toward the back, away from the base assembly before installing the display assembly.

1. Follow the instructions in [Before Working on Your Computer](#).
2. Close the display and turn the computer over.
3. Remove the bottom of the base assembly (see [Removing the Bottom of the Base Assembly](#)).
4. Remove the hinge covers (see [Removing the Hinge Covers](#)).
5. Disconnect the display cable and the wireless antenna cables.
6. Remove the display cable and the wireless antenna cables (WLAN, WWAN, and WPAN) from their routing channels. Position all cables to the rear and away from the laptop.

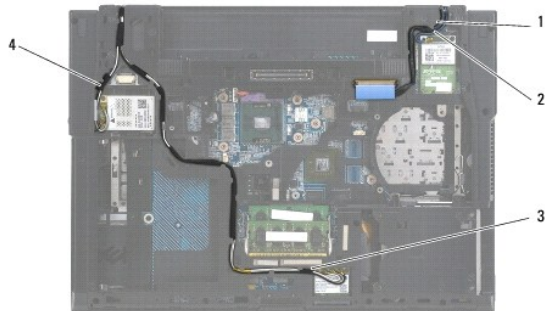

1	display cable	2	WPAN antenna cable
3	WLAN antenna cable	4	WWAN antenna cable

7. Remove the two M2.5 x 5-mm screws from the hinges.



1	M2.5 x 5-mm screws (2)		
---	------------------------	--	--

8. Turn the computer topside up.
9. Open the display to 90 degrees and lift the display assembly off the base assembly.



1	display assembly	2	base assembly
---	------------------	---	---------------

---

## Replacing the Display Assembly

**⚠ CAUTION:** Before working inside your computer, read the safety information that shipped with your computer. For additional safety best practices information, see the Regulatory Compliance Homepage on [www.dell.com](http://www.dell.com) at: [www.dell.com/regulatory\\_compliance](http://www.dell.com/regulatory_compliance).

1. Align the display hinges with the holes in the base of the computer, and lower the display into place.
2. Replace the two M2.5 x 5-mm screws on the hinges.
3. Close the display and turn the computer over.
4. Route the display cable and antenna (WLAN, WWAN, and WPAN) cables. Ensure that they are retained in the routing channels by the tabs provided.
5. Connect the WWAN antenna cables to the WWAN card. Place any unused antenna cables in the base assembly cable holders next to the card slot.
6. Connect the WPAN antenna cable to the WPAN card. Place any unused antenna cables in the base assembly cable holders next to the card slot.
7. Connect the WLAN antenna cables to the WLAN card. Place any unused antenna cables in the base assembly cable holders next to the card slot.
8. Connect the display cable to the display cable connector on the system board.
9. Replace the hinge covers (see [Replacing the Hinge Covers](#)).
10. Replace the bottom of the base assembly (see [Replacing the Bottom of the Base Assembly](#)).
11. Replace the battery (see [Replacing the Battery](#)).

---

## Removing the Display Bezel

**⚠ CAUTION:** Before working inside your computer, read the safety information that shipped with your computer. For additional safety best practices information, see the Regulatory Compliance Homepage on [www.dell.com](http://www.dell.com) at: [www.dell.com/regulatory\\_compliance](http://www.dell.com/regulatory_compliance).

1. Follow the instructions in [Before Working on Your Computer](#).
  2. Remove the display assembly (see [Removing the Display Assembly](#)).
- ➡ NOTICE:** Removal of the bezel from the display back cover requires extreme care to avoid damage to the bezel.

➡ **NOTICE:** To release the snaps on the left and right sides of the bezel, push the bezel sides away or out from the LCD, while lifting up. To release the snaps along the top and bottom of the bezel, pull the bezel top or bottom toward or in to the LCD, while lifting up.

3. Follow the **NOTICES** above to carefully release all bezel snaps. Special attention is required for the corners, especially for the bezels used with LED LCD panels.
4. Once all snaps are released, lift the bezel from the display assembly.

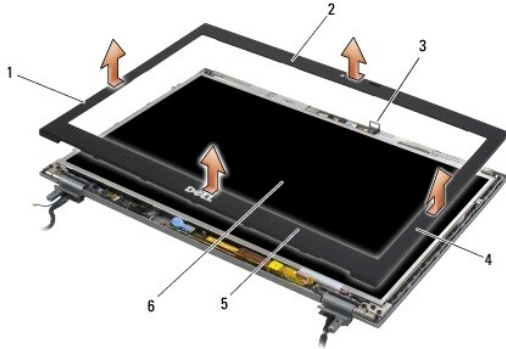

1	left side of display bezel	2	top of display bezel
3	latch hook on display panel	4	right side of display bezel
5	bottom of display bezel	6	display panel

---

## Replacing the Display Bezel

⚠ **CAUTION:** Before working inside your computer, read the safety information that shipped with your computer. For additional safety best practices information, see the Regulatory Compliance Homepage on [www.dell.com](http://www.dell.com) at: [www.dell.com/regulatory\\_compliance](http://www.dell.com/regulatory_compliance).

1. Align the latch hook on the display panel with the small rectangular opening on the display bezel.

➡ **NOTICE:** To engage the snaps on the left and right sides of the bezel, pull the bezel sides toward or in to the LCD, while pushing down. To engage the snaps along the top and bottom of the bezel, push the bezel top or bottom away or out from the LCD, while pushing down.

2. Starting at any corner, use your fingers to gently snap the bezel into place to secure it to the display panel.
3. Replace the display assembly (see [Replacing the Display Assembly](#)).

---

## Removing the Display Panel

The Dell Precision M4400 laptop includes either a CCFL display panel or an LED display panel. Use the procedure applicable to the configuration of the laptop you are disassembling.

### Removing a CCFL Display Panel

⚠ **CAUTION:** Before working inside your computer, read the safety information that shipped with your computer. For additional safety best practices information, see the Regulatory Compliance Homepage on [www.dell.com](http://www.dell.com) at: [www.dell.com/regulatory\\_compliance](http://www.dell.com/regulatory_compliance).

1. Follow the instructions in [Before Working on Your Computer](#).
2. Remove the display assembly (see [Removing the Display Assembly](#)).
3. Remove the display bezel (see [Removing the Display Bezel](#)).
4. Disconnect the inverter backlight cable from the inverter.
5. Remove the four M2.5 x 5-mm screws from the display panel.

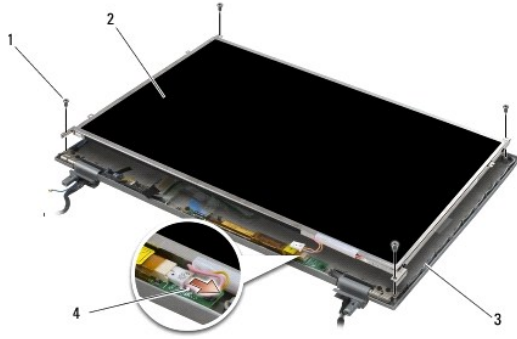

1	M2.5 x 5-mm screw (4)	2	display panel
3	display cover	4	inverter backlight cable

- Lift the display panel out of the display cover and lay the display panel flat on your workspace. Use extreme care when handling the display near the hinges and cables on the display cover to prevent damage to the display.
- Disconnect the display cable by first squeezing the release tabs together, then separating the cable from of the connector.

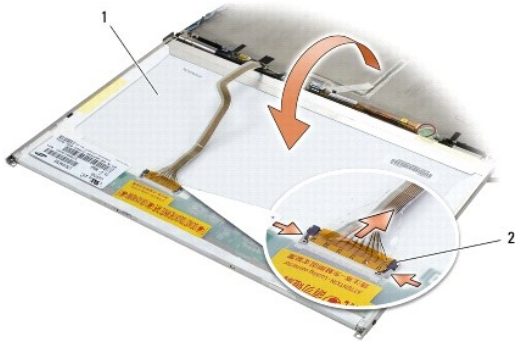

1	back of display panel	2	display panel cable connector
---	-----------------------	---	-------------------------------

- Remove the four M2 x 3-mm screws from both the right and the left display panel brackets.

## Removing an LED Display Panel

**⚠ CAUTION:** Before working inside your computer, read the safety information that shipped with your computer. For additional safety best practices information, see the Regulatory Compliance Homepage on [www.dell.com](http://www.dell.com) at: [www.dell.com/regulatory\\_compliance](http://www.dell.com/regulatory_compliance).

- Follow the instructions in [Before Working on Your Computer](#).
- Remove the display assembly (see [Removing the Display Assembly](#)).
- Remove the display bezel (see [Removing the Display Bezel](#)).
- Remove the four M2.5 x 5-mm screws that anchor the display panel.

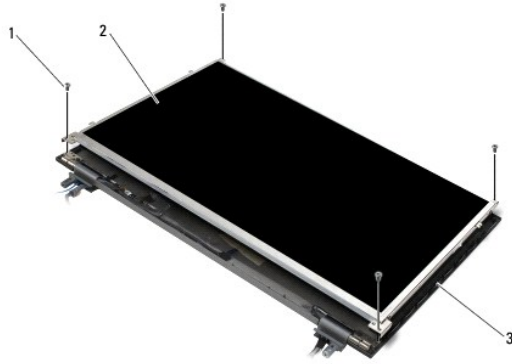

1	M2.5 x 5-mm screw (4)	2	display panel
3	display cover		

- Lift the display panel out of the display cover and lay the display panel flat on your workspace. Use extreme care when handling the display near the hinges and cables on the display cover to prevent damage to the display.
- Disconnect the display cable using the pull tab.

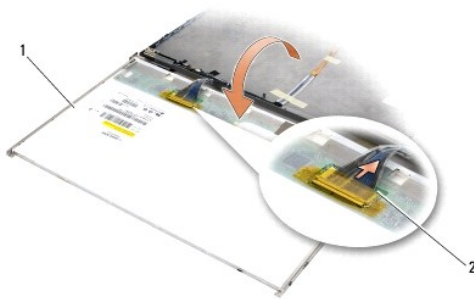

1	back of display panel	2	display panel cable connector
---	-----------------------	---	-------------------------------

- Remove the two M2 x 3-mm screws from both the right and left display panel brackets, then remove the brackets.

## Replacing the Display Panel

The Dell Precision M4400 laptop includes either a CCFL display panel or an LED display panel. Use the procedure applicable to the configuration of the laptop you are assembling.

### Replacing a CCFL Display Panel

**CAUTION:** Before working inside your computer, read the safety information that shipped with your computer. For additional safety best practices information, see the Regulatory Compliance Homepage on [www.dell.com](http://www.dell.com) at: [www.dell.com/regulatory\\_compliance](http://www.dell.com/regulatory_compliance).

**NOTE:** The display panel brackets are labeled L (left) and R (right).

- Attach the display panel brackets to the display panel using four M2 x 3-mm screws for each bracket.
- Place the display panel upside down on your workspace, in front of the display cover. Connect the backlight cable to the inverter. Connect the display cable to the connector on the back of the display panel.
- Position the display panel in the display cover. Use the alignment posts in the display cover to align each bracket.
- Connect the display cable to the connector on the back of the display panel.

5. Route the display cable around the notch on the display cover and set the display panel in place.
6. Replace the four M2.5 x 5-mm screws that secure the display panel to the display cover.
7. Replace the display bezel (see [Replacing the Display Bezel](#)).
8. Replace the display assembly (see [Replacing the Display Assembly](#)).

## Replacing an LED Display Panel

**⚠ CAUTION:** Before working inside your computer, read the safety information that shipped with your computer. For additional safety best practices information, see the Regulatory Compliance Homepage on [www.dell.com](http://www.dell.com) at: [www.dell.com/regulatory\\_compliance](http://www.dell.com/regulatory_compliance).

**🔍 NOTE:** The display panel brackets are labeled L (left) and R (right).

1. Replace the two (each) M2 x 3-mm screws on the right and left display panel brackets.
  2. Connect the display cable to the connector on the back of the display panel.
  3. Route the display cable around the notch on the display cover and set the display panel in place.
  4. Replace the four M2.5 x 5-mm screws that secure the display panel to the display cover.
  5. Replace the display bezel (see [Replacing the Display Bezel](#)).
  6. Replace the display assembly (see [Replacing the Display Assembly](#)).
- 

## Display Inverter

### Removing the Display Inverter

**⚠ CAUTION:** Before working inside your computer, read the safety information that shipped with your computer. For additional safety best practices information, see the Regulatory Compliance Homepage on [www.dell.com](http://www.dell.com) at: [www.dell.com/regulatory\\_compliance](http://www.dell.com/regulatory_compliance).

1. Follow the instructions in [Before Working on Your Computer](#).
2. Remove the display assembly (see [Removing the Display Assembly](#)).
3. Remove the display bezel (see [Removing the Display Bezel](#)).
4. Remove the M2 x 3-mm screw from the display inverter.
5. Disconnect the two display inverter connectors.
6. Lift the display inverter out of the display cover.

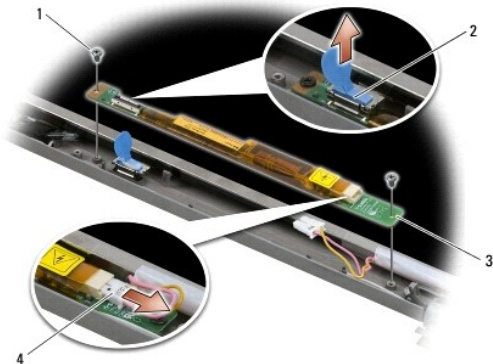

1	M2 x 3-mm screw (2)	2	display inverter connector
3	display inverter	4	display inverter connector

## Replacing the Display Inverter

**⚠ CAUTION:** Before working inside your computer, read the safety information that shipped with your computer. For additional safety best practices information, see the Regulatory Compliance Homepage on [www.dell.com](http://www.dell.com) at: [www.dell.com/regulatory\\_compliance](http://www.dell.com/regulatory_compliance).

1. Connect the two display inverter connectors to the display inverter.
2. Replace the two M2 x 3-mm screws securing the display inverter.
3. Replace the display bezel (see [Replacing the Display Bezel](#)).
4. Replace the display assembly (see [Replacing the Display Assembly](#)).

## Removing the Camera and Microphone Assembly

**⚠ CAUTION:** Before working inside your computer, read the safety information that shipped with your computer. For additional safety best practices information, see the Regulatory Compliance Homepage on [www.dell.com](http://www.dell.com) at: [www.dell.com/regulatory\\_compliance](http://www.dell.com/regulatory_compliance).

1. Follow the instructions in [Before Working on Your Computer](#).
2. Remove the display assembly (see [Removing the Display Assembly](#)).
3. Remove the display bezel (see [Removing the Display Bezel](#)).
4. Lift the small connector lever on the camera/microphone cable.
5. Loosen the M2 x 3-mm captive screw, and carefully lift the camera/microphone assembly up at an angle and disconnect the camera/microphone cable.

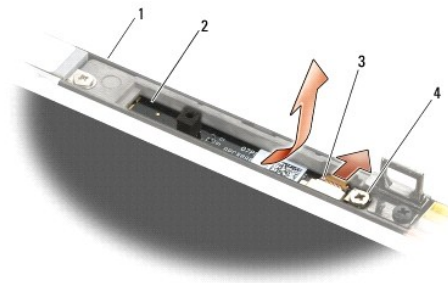

1	display cover	2	camera microphone assembly
3	camera microphone cable	4	M2 x 3-mm screw (1)

## Replacing the Camera and Microphone Assembly

**⚠ CAUTION:** Before working inside your computer, read the safety information that shipped with your computer. For additional safety best practices information, see the Regulatory Compliance Homepage on [www.dell.com](http://www.dell.com) at: [www.dell.com/regulatory\\_compliance](http://www.dell.com/regulatory_compliance).

1. Slide the cable connector of the camera/microphone cable into the connector on the camera/microphone assembly.
2. Close the lever on the connector on the camera/microphone assembly.
3. Angle in and align the camera/microphone assembly with the notch on the display cover.



4. Tighten the M2 x 3-mm screw that secures the camera/microphone assembly to the display cover.
5. Replace the display bezel (see [Replacing the Display Bezel](#)).
6. Replace the display assembly (see [Replacing the Display Assembly](#)).

---

## Removing the Latch Hook

**⚠ CAUTION:** Before working inside your computer, read the safety information that shipped with your computer. For additional safety best practices information, see the Regulatory Compliance Homepage on [www.dell.com](http://www.dell.com) at: [www.dell.com/regulatory\\_compliance](http://www.dell.com/regulatory_compliance).

1. Follow the instructions in [Before Working on Your Computer](#).
2. Remove the display assembly (see [Removing the Display Assembly](#)).
3. Remove the display bezel (see [Removing the Display Bezel](#)).
4. Remove the M2.5 x 5-mm screw.
5. Remove the latch hook from the display cover.

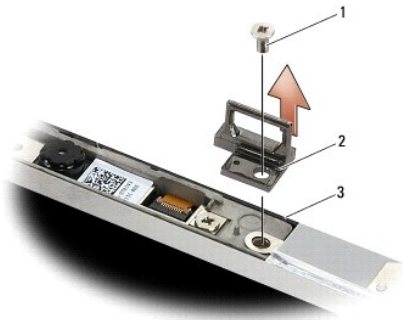

1	M2.5 x 5-mm screw (1)	2	latch hook
3	display cover		

6. [Replacing the Display Assembly](#).

---

## Replacing the Latch Hook

**⚠ CAUTION:** Before working inside your computer, read the safety information that shipped with your computer. For additional safety best practices information, see the Regulatory Compliance Homepage on [www.dell.com](http://www.dell.com) at: [www.dell.com/regulatory\\_compliance](http://www.dell.com/regulatory_compliance).

1. Follow the instructions in [Before Working on Your Computer](#).
2. Position the latch hook on the display cover.
3. Replace the M2.5 x 5-mm screw.
4. Replace the display bezel (see [Replacing the Display Bezel](#)).
5. Replace the display assembly (see [Replacing the Display Assembly](#)).

---

## Removing the Display Bracket

1. Remove the two M2 x 3mm screws from the display bracket.

2. Remove the display bracket.



1	display panel	2	M2 x 3-mm screw (2)
3	display panel bracket		

---

## Replacing the Display Bracket

1. Position the display bracket on the display panel.
2. Replace the two M2 x 3mm screws to secure the display bracket to the panel.

---

## Remove the Display Cover

**⚠ CAUTION:** Before working inside your computer, read the safety information that shipped with your computer. For additional safety best practices information, see the Regulatory Compliance Homepage on [www.dell.com](http://www.dell.com) at: [www.dell.com/regulatory\\_compliance](http://www.dell.com/regulatory_compliance).

**👉 NOTICE:** Position all display assembly cables toward the back, away from the base assembly before installing the display assembly.

1. Follow the instructions in [Before Working on Your Computer](#)
2. Remove the display assembly (see [Removing the Display Assembly](#)).
3. Remove the display bezel (see [Removing the Display Bezel](#)).
4. Remove the display panel (see [Removing the Display Panel](#)).
5. Remove the optional camera and microphone, if present (see [Removing the Camera and Microphone Assembly](#)).

---

## Replace the Display Cover

**⚠ CAUTION:** Before working inside your computer, read the safety information that shipped with your computer. For additional safety best practices information, see the Regulatory Compliance Homepage on [www.dell.com](http://www.dell.com) at: [www.dell.com/regulatory\\_compliance](http://www.dell.com/regulatory_compliance).

1. Remove the tape from the cables that are taped to the display cover.
2. Replace the camera and microphone assembly, if one was removed previously (see [Replacing the Camera and Microphone Assembly](#)).
3. Replace the display panel (see [Replacing the Display Assembly](#)).
4. Replace the display bezel (see [Replacing the Display Bezel](#)).
5. Replace the display assembly (see [Replacing the Display Assembly](#)).
6. Replace the hinge covers (see [Replacing the Hinge Covers](#)).

7. Replace the bottom of the base assembly (see [Replacing the Bottom of the Base Assembly](#)).
8. Follow the procedure [After Working on Your Computer](#).

---

[Back to Contents Page](#)

## Fan

### Dell Precision™ Service Manual

- [Removing the Fan](#)
- [Replacing the Fan](#)

---

## Removing the Fan

**⚠ CAUTION:** Before working inside your computer, read the safety information that shipped with your computer. For additional safety best practices information, see the Regulatory Compliance Homepage on [www.dell.com](http://www.dell.com) at: [www.dell.com/regulatory\\_compliance](http://www.dell.com/regulatory_compliance).

1. Follow the instructions in [Before Working on Your Computer](#).
2. Close the display and turn the computer over.
3. Remove the bottom of the base assembly (see [Removing the Bottom of the Base Assembly](#)).
4. Remove the three M2.5 x 5-mm screws that secure the fan to the internal framework of the computer.
5. Disconnect the fan connector from the system board.
6. Lift the fan up at an angle to remove it.

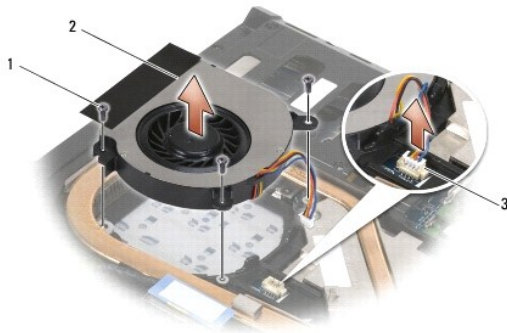

1	M2.5 x 5-mm screws (3)	2	fan
3	fan connector		

---

## Replacing the Fan

**⚠ CAUTION:** Before working inside your computer, read the safety information that shipped with your computer. For additional safety best practices information, see the Regulatory Compliance Homepage on [www.dell.com](http://www.dell.com) at: [www.dell.com/regulatory\\_compliance](http://www.dell.com/regulatory_compliance).

1. Insert the fan into the fan cavity and align the screw holes in the fan with the screw holes in the base assembly.
2. Install the three M2.5 x 5-mm screws to secure the fan.
3. Connect the fan connector to the system board connector.
4. Replace the bottom of the base assembly (see [Replacing the Bottom of the Base Assembly](#)).
5. Follow the procedure [After Working on Your Computer](#).



## Flash Cache Module

### Dell Precision™ Service Manual

- [Removing an FCM](#)
- [Replacing an FCM](#)

**⚠ CAUTION:** Before working inside your computer, read the safety information that shipped with your computer. For additional safety best practices information, see the Regulatory Compliance Homepage on [www.dell.com](http://www.dell.com) at: [www.dell.com/regulatory\\_compliance](http://www.dell.com/regulatory_compliance).

The Flash Cache Module (FCM) is an internal memory module that helps improve the performance of your computer. You can install the module in either the WWAN or WPAN Mini-Card slot.

**🔍 NOTE:** This card is only compatible with the Windows Vista® operating system.

If you ordered an FCM with your computer, the card is already installed.

---

## Removing an FCM

1. Follow the procedures in [Before Working on Your Computer](#).
2. Remove the bottom of the base assembly (see [Removing the Bottom of the Base Assembly](#)).
3. If removing a module from the WPAN Mini-Card slot, remove the left hinge cover (see [Removing the Hinge Covers](#)).
4. Remove the M2 x 3-mm screw from the FCM. The module pops up to a 30-degree angle to the system board.
5. Slide the FCM out of its connector.

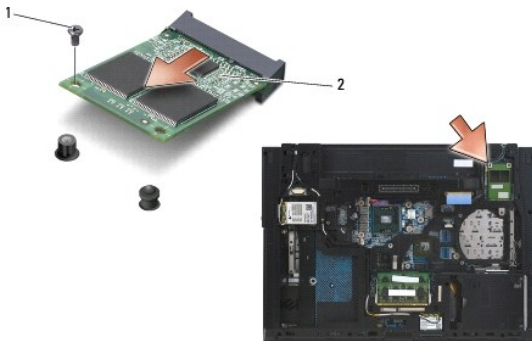

1	M2 x 3-mm screw	2	WPAN/UWB/FCM card
---	-----------------	---	-------------------

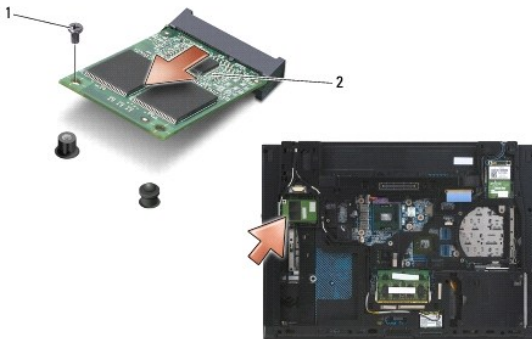

1	M2 x 3-mm screw	2	WWAN/FCM card
---	-----------------	---	---------------

---

## Replacing an FCM

- ➡ **NOTICE:** The connectors are keyed to ensure correct insertion. If you feel resistance, check the connectors on the module and on the system board, and realign the module.
- ➡ **NOTICE:** To avoid damage to the FCM, ensure the cables are not under the module when you install it.
- ➡ **NOTICE:** The Mini-Card slot has WPAN/UWB/FCM silk-screened inside the slot. Do not install an FCM in any other Mini-Card slot.

1. Slide the FCM into the connector at a 30-degree angle to the system board.
2. Press the module down onto the alignment post and hold in position.
3. Replace the screw to secure the FCM to the base assembly.
4. Replace the left hinge cover (see [Replacing the Hinge Covers](#)) if necessary.
5. Replace the bottom of the base assembly (see [Removing the Bottom of the Base Assembly](#)).
6. Follow the procedure [After Working on Your Computer](#).

---

[Back to Contents Page](#)

[Back to Contents Page](#)

## Hard Drive

### Dell Precision™ Service Manual

- [Removing the Hard Drive](#)
- [Replacing the Hard Drive](#)

 **NOTE:** Dell does not guarantee compatibility or provide support for hard drives obtained from sources other than Dell.

---

## Removing the Hard Drive

 **CAUTION:** Before working inside your computer, read the safety information that shipped with your computer. For additional safety best practices information, see the Regulatory Compliance Homepage on [www.dell.com](http://www.dell.com) at: [www.dell.com/regulatory\\_compliance](http://www.dell.com/regulatory_compliance).

 **CAUTION:** Do not touch the metal housing of the hard drive if you remove the hard drive from the computer while the drive is hot.

 **NOTICE:** To prevent data loss, turn off your computer before removing the hard drive. Do not remove the hard drive while the computer is on or in Sleep state.

 **NOTE:** Hard drives are extremely fragile. Exercise care when handling the hard drive.

To remove the hard drive in the hard drive bay:

1. Follow the procedures in [Before Working on Your Computer](#).
2. Place the computer upside down on a clean, flat surface.

 **NOTICE:** When the hard drive is not in the computer, store it in protective anti-static packaging.

3. Remove the four M3 x 3-mm screws securing the hard drive. These screws are marked by a  symbol on the bottom of the base assembly.

 **NOTE:** If the bottom of the base assembly is detached from the laptop, the four screws securing the hard drive are marked with an "H".

4. Slide the hard drive out of the computer.

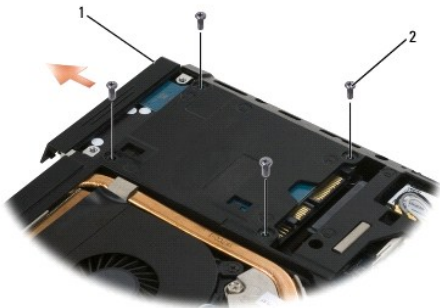

1	hard drive	2	M3 x 3-mm screw (4)
---	------------	---	---------------------

5. Remove the face plate screw and then the face plate from the hard drive.



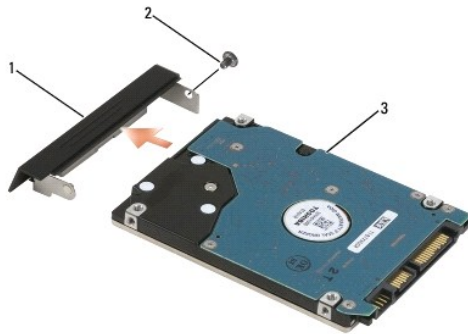

1	hard drive face plate	2	M2 x 3-mm screw
3	hard drive		

---

## Replacing the Hard Drive

1. If replacing the hard drive with a new one, remove the new drive from its packaging.

Save the original packaging for storing or shipping the hard drive.

2. If the face plate is detached from the hard drive, attach it with a M2 x 3-mm screw.

**NOTICE:** Use firm and even pressure to slide the drive into place. If you use excessive force, you may damage the connector.

3. Slide the hard drive into the bay until it is fully seated.
4. Replace and tighten the four M3 x 3-mm hard-drive screws.
5. Follow the procedure [After Working on Your Computer](#).
6. Start up your computer.
7. If you have installed a new or different hard drive, try to restart your computer. If it doesn't restart:
  - 1 use your *Operating System* installation media to install the operating system for your computer (see your *Setup and Quick Reference Guide* for information).
  - 1 use the *Drivers and Utilities* media to install the drivers and utilities for your computer (see your *Setup and Quick Reference Guide* for information).

---

[Back to Contents Page](#)

## Hinge Covers

### Dell Precision™ Service Manual

- [Removing the Hinge Covers](#)
- [Replacing the Hinge Covers](#)

---

## Removing the Hinge Covers

**⚠ CAUTION:** Before you begin any of the procedures in this section, follow the safety instructions that shipped with your computer.

The hinge covers are not interchangeable; the left one covers the multimode DisplayPort and the right one covers the RJ-45 network connector.

1. Follow the procedures in [Before Working on Your Computer](#).
2. Close the display and turn the computer over.
3. Remove the bottom of the base assembly (see [Removing the Bottom of the Base Assembly](#)).
4. Remove the two M2.5 x 5-mm screws from each hinge cover.
5. Slide each hinge cover off the computer and lift to remove it.

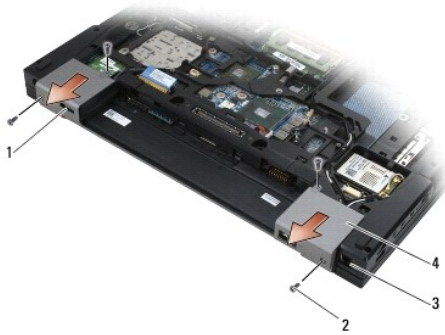

1	display port	2	M2.5 x 5-mm screw (4)
3	RJ-11 network connector	4	hinge cover (2)

---

## Replacing the Hinge Covers

1. Slide the left hinge cover over the display port and slide the right hinge cover over the RJ-45 network connector.
2. Replace the M2.5x5-mm screws in each hinge cover.
3. Replace the bottom of the base assembly (see [Replacing the Bottom of the Base Assembly](#)).
4. Follow the procedure [After Working on Your Computer](#).

## Keyboard

### Dell Precision™ Service Manual

- [Removing the Keyboard](#)
- [Replacing the Keyboard](#)

---

## Removing the Keyboard

**⚠ CAUTION:** Before you begin any of the procedures in this section, follow the safety instructions that shipped with your computer.

1. Follow the procedures in [Before Working on Your Computer](#).
2. Remove the LED cover (see [Removing the LED Cover](#)).
3. Remove the two M2 x 3-mm screws along the top of the keyboard.

**👉 NOTICE:** The key caps on the keyboard are fragile, easily dislodged, and time-consuming to replace. Exercise care when removing and handling the keyboard.

4. Using the pull tab, gently lift the top of the keyboard only, then lift out at an angle to remove the keyboard from its connector.

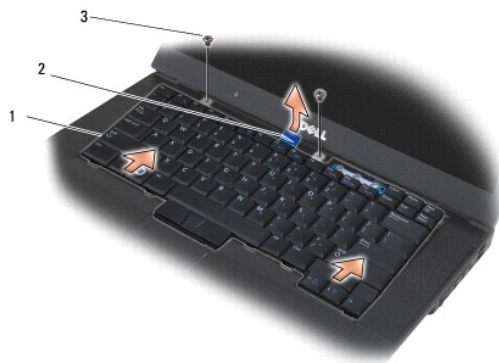

1	keyboard	2	blue pull tab
3	M2 x 3-mm screw (2)		

---

## Replacing the Keyboard

**⚠ CAUTION:** Before you begin any of the procedures in this section, follow the safety instructions that shipped with your computer.

**👉 NOTICE:** The key caps on the keyboard are fragile, easily dislodged, and time-consuming to replace. Exercise care when removing and handling the keyboard.

1. Holding the top of the keyboard slightly above the computer, slide the bottom of the keyboard in at an angle, and fit the tabs and keyboard connector along the bottom of the keyboard beneath the front-inside edge of the palm rest.

**🔧 NOTE:** Pressing down on the ALT keys helps to seat the keyboard properly.

2. Carefully press each side to snap the keyboard into place.
3. Replace the two M2 x 3-mm screws at the top of the keyboard.



1	keyboard connector	2	tabs (5)
3	M2 x 3-mm screw (2)		

4. Replace the LED cover (see [Replacing the LED Cover](#)).
5. Close the display and turn the computer over.
6. Follow the procedure [After Working on Your Computer](#).

---

[Back to Contents Page](#)

[Back to Contents Page](#)

## LED Cover

Dell Precision™ Service Manual

- [Removing the LED Cover](#)
- [Replacing the LED Cover](#)

---

### Removing the LED Cover

**⚠ CAUTION:** Before you begin any of the procedures in this section, follow the safety instructions that shipped with your computer.

1. Follow the procedures in [Before Working on Your Computer](#).
2. Open the display.
3. Using a plastic scribe, lift the right end of the LED cover. Lift the remainder of the cover to remove it from the laptop.



1	LED cover	2	scribe
---	-----------	---	--------

---

### Replacing the LED Cover

**⚠ CAUTION:** Before you begin any of the procedures in this section, follow the safety instructions that shipped with your computer.

1. Snap the LED cover back into place one tab at a time.
2. Follow the procedure [After Working on Your Computer](#).

---

[Back to Contents Page](#)

## Memory

### Dell Precision™ Service Manual

- [Removing a Memory Module](#)
- [Replacing a Memory Module](#)
- [Verifying System Operation](#)

 **CAUTION:** Before you begin any of the procedures in this section, follow the safety instructions in the *Dell™ Product Information Guide*.

 **CAUTION:** To avoid electrostatic discharge, ground yourself by using a wrist grounding strap or by periodically touching an unpainted metal surface, such as a connector on the back of the computer.

 **NOTICE:** If your computer has only one memory module, install the memory module in the socket labeled "DIMM A".

 **NOTICE:** If you remove your original memory modules from the computer during a memory upgrade, keep them separate from any new modules that you may have, even if you purchased the new modules from Dell. If possible, *do not* pair an original memory module with a new memory module. Otherwise, your computer may not function at optimal performance.

 **NOTE:** Memory modules purchased from Dell are covered under your computer warranty.

## Removing a Memory Module

Your system supports the following memory configurations:

Size	Slot	Windows XP	Windows Vista
512 MB	DIMM A	X	X
1 GB	DIMM A or DIMM A and DIMM B	X	X
2 GB	DIMM A or DIMM A and DIMM B	X	X
3 GB	DIMM A and DIMM B	X	X
4 GB	DIMM A or DIMM A and DIMM B		X
8 GB	DIMM A and DIMM B		X

Your computer has two user-accessible SODIMM sockets, referred to as DIMM A and DIMM B. The socket closest to the system board, DIMM A, always contains a memory module. The DIMM B socket may contain an additional module for improved system memory performance. If the module in the DIMM A socket must be replaced and DIMM B is installed, DIMM B must be removed first.

1. Follow the procedures in [Before Working on Your Computer](#).
2. Lay the computer upside down onto a clean, flat surface.
3. Remove the bottom of the base assembly (see [Removing the Bottom of the Base Assembly](#)).

## DIMM B

The DIMM B socket may or may not be populated with a memory module, depending on the configuration of your system. When viewing the memory compartment from the underside of the computer, the DIMM B socket is uppermost and DIMM A is closest to the system board.

## Removing the DIMM B Module

 **NOTICE:** To prevent damage to the memory module connector, do not use tools to spread the memory-module retaining clips.

1. To remove the DIMM B module, spread away the retaining clips from the side edges of the memory module and lift the free edge of the module so that it sits at about a 30-degree angle to the system board.

1	memory-module retaining clips (2)	2	memory module
3	DIMM B module	4	DIMM A module

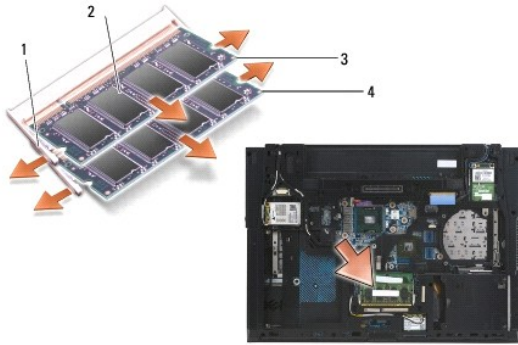

2. Grasp the module at the side edges and pull it straight away from the connector. Place the module into anti-static packaging such as an anti-static bag.

## DIMM A

➡ **NOTICE:** To prevent damage to the memory module connector, do not use tools to spread the memory-module retaining clips.

1. To remove the DIMM A module, spread away the retaining clips from the side edges of the memory module and lift the free edge of the module so that it sits at about a 30-degree angle to the system board.
2. Grasp the module at the side edges and pull it straight away from the connector. Place the module into anti-static packaging such as an anti-static bag.

## Replacing a Memory Module

### DIMM A

The DIMM A socket is the one closest to the system board. If a memory module is installed in the DIMM B socket, it must be removed before a memory module in the DIMM A socket can be replaced.

1. Ground yourself by touching a bare-metal part in the computer chassis.
2. Remove the memory module from its anti-static packaging and, grasping the module at the side edges, align the slot in the module edge connector with the key in the DIMM A socket connector.
3. Slide the memory module into the socket connector at a 30-degree angle to the system board until it is fully seated.

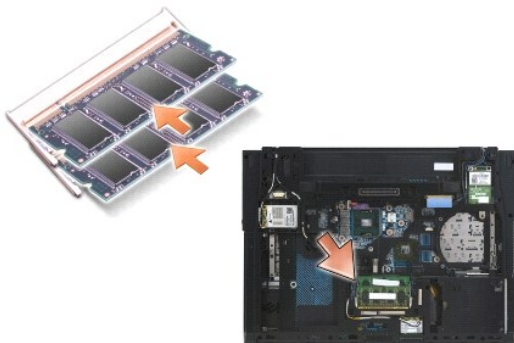

4. Push the long edge of the memory module down until retaining clips lock the module into place.

🔍 **NOTE:** If the memory module is not installed properly, the retaining clips will not hold the module securely and the computer may not boot properly. No error message indicates this failure.

5. If a memory module is installed into the DIMM B socket, replace it using procedures in [DIMM B](#).

## DIMM B

1. Ground yourself by touching a bare-metal part in the computer chassis.
2. Remove the memory module from its anti-static packaging and, grasping the module at the side edges, align the slot in the module edge connector with the key in the socket connector.
3. Slide the memory module into the DIMM B connector at a 30-degree angle to the system board until it is fully seated.
4. Push the long edge of the memory module down until retaining clips lock the module in place.

 **NOTE:** If the memory module is not installed properly, the retaining clips will not hold the module securely and the computer may not boot properly. No error message indicates this problem.

---

## Verifying System Operation

1. Slide the bottom of the base assembly into place and tighten the captive screw.
2. Follow the procedure [After Working on Your Computer](#).
3. Set the computer upright and open the display.
4. Power-on your computer. As the computer boots, it detects the additional memory and automatically updates the system configuration information. Verify that the memory capacity shown on the display is what is expected.
5. To confirm the amount of memory installed in the computer:
  - 1 In the Microsoft® Windows Vista® operating system, click **Start**  → **Help and Support** → **Computer Information**.
  - 1 In the Microsoft Windows® XP operating system, right-click the **My Computer** icon on your desktop, click **Properties**, and then click **General**.

---

[Back to Contents Page](#)



## Modem

### Dell Precision™ Service Manual

- [Removing the Modem](#)
- [Replacing the Modem](#)

---

## Removing the Modem

**⚠ CAUTION:** Before working inside your computer, read the safety information that shipped with your computer. For additional safety best practices information, see the Regulatory Compliance Homepage on [www.dell.com](http://www.dell.com) at: [www.dell.com/regulatory\\_compliance](http://www.dell.com/regulatory_compliance).

1. Follow the procedures in [Before Working on Your Computer](#).
2. Close the display and turn the computer over.
3. Remove the battery (see [Removing the Battery](#)).
4. Remove the bottom of the base assembly (see [Removing the Bottom of the Base Assembly](#)).
5. Remove the orange modem flex cable from the I/O board by pushing the tabs forward and removing the cable.
6. Remove the M2 x 3-mm screw from the modem.
7. Remove the black RJ11 modem cable from the modem.
8. Remove the modem.

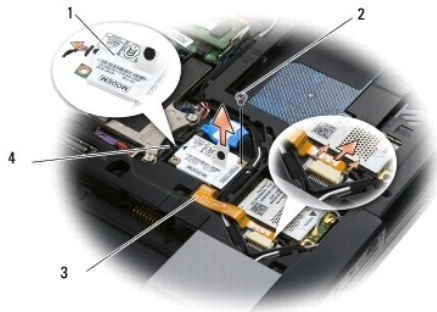

1	modem	2	M2 x 3-mm screw
3	orange modem flex cable	4	black RJ11 modem cable

---

## Replacing the Modem

**⚠ CAUTION:** Before working inside your computer, read the safety information that shipped with your computer. For additional safety best practices information, see the Regulatory Compliance Homepage on [www.dell.com](http://www.dell.com) at: [www.dell.com/regulatory\\_compliance](http://www.dell.com/regulatory_compliance).

1. Attach the black RJ11 modem cable to the modem.
2. Place the modem into the base assembly.
3. Replace the M2 x 3-mm screw to secure the modem to the I/O board.
4. Connect the orange modem flex cable to the I/O board.
5. Replace the bottom of the base assembly (see [Replacing the Bottom of the Base Assembly](#)).

6. Follow the procedure [After Working on Your Computer](#).

---

[Back to Contents Page](#)

## Modular Drive

### Dell Precision™ Service Manual

- [Removing the Modular Drive](#)
- [Replacing the Modular Drive](#)

The modular drive bay supports either a second hard drive, an optical drive, or an air bay for travel.

---

## Removing the Modular Drive

**CAUTION:** Before you begin any of the procedures in this section, follow the safety instructions that shipped with your computer.

**NOTE:** The modular drive security screw is optional and may not be installed on your computer.

1. Follow the procedures in [Before Working on Your Computer](#).
2. Close the display and turn the computer over.
3. If a security screw is in place, remove it from the drive.
4. Push the drive lever in to release it.
5. Pull the drive out of the modular bay.

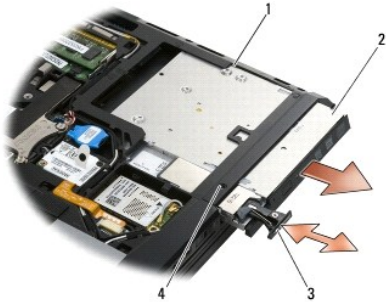

1	modular bay	2	modular drive
3	drive lever	4	security screw (optional)

## Replacing the Modular Drive

**CAUTION:** Before you begin any of the procedures in this section, follow the safety instructions that shipped with your computer.

**NOTE:** The modular drive security screw is optional and may not be installed on your computer.

1. Slide the drive into the modular bay until it is properly seated.
  2. Push the release latch in to secure the drive.
  3. If a security screw was removed, replace the security screw.
  4. Follow the procedure [After Working on Your Computer](#).
-

## Palm Rest Assembly

### Dell Precision™ Service Manual

- [Removing the Palm Rest Assembly](#)
- [Replacing the Palm Rest Assembly](#)

## Removing the Palm Rest Assembly

**⚠ CAUTION:** Before working inside your computer, read the safety information that shipped with your computer. For additional safety best practices information, see the Regulatory Compliance Homepage on [www.dell.com](http://www.dell.com) at: [www.dell.com/regulatory\\_compliance](http://www.dell.com/regulatory_compliance).

1. Follow the instructions in [Before Working on Your Computer](#).
2. Remove the bottom of the base assembly (see [Removing the Bottom of the Base Assembly](#)).
3. Remove the hard drive (see [Removing the Hard Drive](#)).
4. Remove the modular drive (see [Removing the Modular Drive](#)).
5. Remove the fan and the two heat sinks (see [Heat Sinks](#)).
6. Remove the hinge covers (see [Removing the Hinge Covers](#)).
7. Remove the display assembly (see [Display Assembly](#)).
8. Remove the keyboard (see [Removing the Keyboard](#)).
9. Turn the computer over and remove ten M2.5 x 5-mm screws and one M2.5 x 8-mm screw.
10. Loosen the three captive screws on the underside of the laptop with the front edge toward you:
  - 1 One screw near the front of the right-side edge of the laptop
  - 1 One in the middle of the left side edge of the laptop
  - 1 One near the upper left corner, marked with an "S".

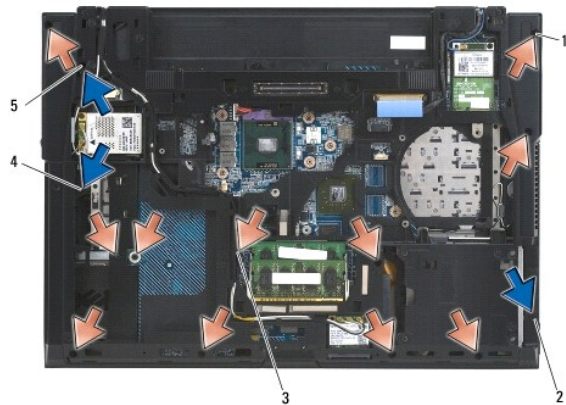

1	M2.5 x 5-mm screw (10)	2	captive screw (near hard drive)
3	M2.5 x 8-mm screw (1)	4	captive screw (near optical bay)
5	captive screw (near I/O card)		

11. Turn the computer topside up and remove the four M2.5 x 5-mm screws that secure the thermal plate, then remove the thermal plate.

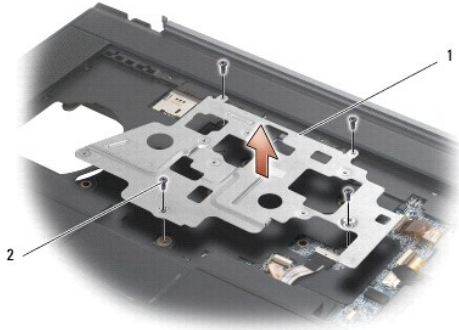

1	thermal plate	2	M2.5 x 4-mm screw (4)
---	---------------	---	-----------------------

12. Disconnect the wireless catcher cable from the system board.
13. Disconnect the speaker cable from the system board.
14. Use the pull tab to disconnect the touch pad cable from the system board.
15. Lift up on the lever to disconnect the contactless smartcard cable from the system board.
16. Lift up on the lever to disconnect the fingerprint reader cable from the system board (optional).

**NOTICE:** Do not use force to separate the palm rest from the computer. If you encounter resistance, gently *flex* or apply pressure to the palm rest, or move along the edge, working away from the area of resistance, until the palm rest is free.

17. Lift the left side of the palm rest, then push in on the right side to release the palm rest, then gently lift it up from the computer. Before lifting the palm rest free of the computer, disconnect the suspend-switch cable attached to the I/O board.
18. With the palm rest laid top down, remove the screws securing the left and right speakers and remove the speakers.

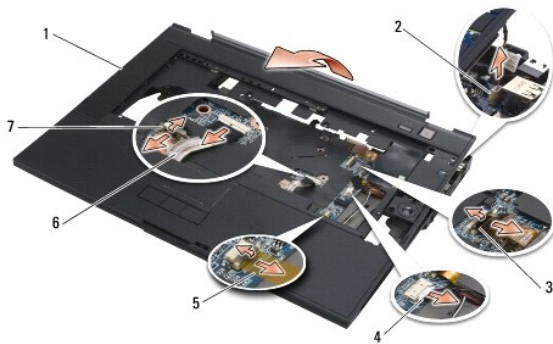

1	palm rest	2	suspend switch cable
3	smartcard reader cable	4	speaker cable
5	fingerprint reader cable	6	contactless smartcard reader cable
7	touchpad cable		

## Replacing the Palm Rest Assembly

**CAUTION:** Before working inside your computer, read the safety information that shipped with your computer. For additional safety best practices information, see the Regulatory Compliance Homepage on [www.dell.com](http://www.dell.com) at: [www.dell.com/regulatory\\_compliance](http://www.dell.com/regulatory_compliance).

1. Attach the left and right speakers to the palm rest using two screws for each. Route the speaker cable through the palm rest assembly.
2. Position the palm rest assembly over the computer and attach the cable from the palm rest assembly to the I/O board.

3. Lower the palm rest onto the computer ensuring that the cable to the I/O board is not pinched and the RJ-11 connector is properly seated.
  4. Angle and connect the right side of the palm rest, then lower and snap the left side into place.
  5. Turn the computer assembly upside down with the front edge toward you, and tighten the three captive screws:
    - 1 One near the front of the right-side edge of the laptop
    - 1 One in the middle of the left side edge of the laptop
    - 1 One near the upper left corner, marked with an "S"
  6. Turn the computer topside up.
  7. Place the thermal plate into position, then replace the four M2.5 x 5-mm screws to secure it.
  8. Connect the contactless smartcard cable, the touchpad cable, the speaker cable, the wireless switch cable, and the fingerprint reader cable (optional) to the system board.
  9. Turn the computer over and replace the ten M2.5 x 5.5-mm screws and the one M2.5 x 8-mm screw on the bottom of the computer to secure the palm rest.
  10. Replace the discrete graphics heat sink (see [Replacing the Discrete Graphics Heat Sink](#)).
  11. Replace the processor heat sink (see [Replacing the Processor Heat Sink](#)).
  12. Replace the fan (see [Replacing the Fan](#)).
  13. Replace the optical drive (see [Replacing the Modular Drive](#)).
  14. Turn the computer topside up and replace the keyboard (see [Replacing the Keyboard](#)).
  15. Replace the display assembly (see [Display Assembly](#)).
  16. Replace the hinge covers (see [Replacing the Hinge Covers](#)).
  17. Replace the bottom of the base assembly (see [Replacing the Bottom of the Base Assembly](#)).
  18. Replace the optical drive (see [Replacing the Modular Drive](#)).
  19. Replace the hard drive (see [Replacing the Hard Drive](#)).
  20. Follow the procedure [After Working on Your Computer](#).
- 

[Back to Contents Page](#)

## DC Power Cable

### Dell Precision™ Service Manual

- [Removing the DC Power Cable](#)
  - [Replacing the DC Power Cable](#)
- 

## Removing the DC Power Cable

**⚠ CAUTION:** Before working inside your computer, read the safety information that shipped with your computer. For additional safety best practices information, see the Regulatory Compliance Homepage on [www.dell.com](http://www.dell.com) at: [www.dell.com/regulatory\\_compliance](http://www.dell.com/regulatory_compliance).

1. Follow the instructions in [Before Working on Your Computer](#).
2. Close the display and turn the computer over.
3. Remove the battery (see [Removing the Battery](#)).
4. Remove the hard drive (see [Removing the Hard Drive](#)).
5. Remove the bottom of the base assembly (see [Removing the Bottom of the Base Assembly](#)).
6. Remove the modular drive (see [Removing the Modular Drive](#)).
7. Remove the hinge covers (see [Removing the Hinge Covers](#)).
8. Remove the display assembly (see [Removing the Display Assembly](#)).
9. Remove the keyboard (see [Removing the Keyboard](#)).
10. Remove the fan (see [Removing the Fan](#)).
11. Remove the processor heat sink (see [Removing the Processor Heat Sink](#)).
12. Remove the discrete graphics heat sink (see [Removing the Discrete Graphics Heat Sink](#)).
13. Remove the fingerprint reader/speaker cover (see [Removing the Right Speaker Grill and Fingerprint Reader](#)).
14. Remove the palm rest assembly (see [Removing the Palm Rest Assembly](#)).
15. Remove the card cage (see [Removing the Express Card Cage](#)).
16. Remove three M2.5 x 5-mm screws labeled with white arrows from the system board.
17. Remove the system board (see [Removing the System Board Assembly](#)). Do not remove the wireless card, memory or processor from the system board.
18. Pull out on the top, left corner of the base assembly to release the DC power, USB, and display connectors.
19. Remove the DC power cable assembly from the base assembly.

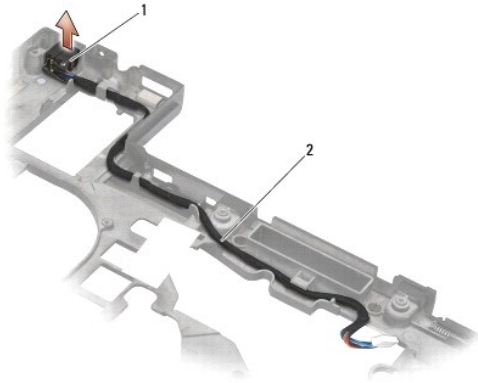

1	DC power connector	2	DC cable
---	--------------------	---	----------

---

## Replacing the DC Power Cable

**⚠ CAUTION:** Before working inside your computer, read the safety information that shipped with your computer. For additional safety best practices information, see the Regulatory Compliance Homepage on [www.dell.com](http://www.dell.com) at: [www.dell.com/regulatory\\_compliance](http://www.dell.com/regulatory_compliance).

1. Position the DC power connector in the base assembly, aligning the guides on the connector sides with the base.
2. Route the DC power cable through the base assembly.
3. Replace the system board (see [Replacing the System Board Assembly](#)).
4. Replace the card cage (see [Replacing the Express Card Cage](#)).
5. Replace the palm rest (see [Replacing the Palm Rest Assembly](#)).
6. Replace the speaker grill and fingerprint reader cover (see [Replacing the Right Speaker Grill and Fingerprint Reader](#)).
7. Replace the discrete graphics heat sink (see [Replacing the Discrete Graphics Heat Sink](#)).
8. Replace the processor heat sink (see [Replacing the Processor Heat Sink](#)).
9. Replace the fan (see [Replacing the Fan](#)).
10. Replace the keyboard (see [Replacing the Keyboard](#)).
11. Replace the LED cover (see [Replacing the LED Cover](#)).
12. Replace the display assembly (see [Replacing the Display Assembly](#)).
13. Replace the hinge covers (see [Replacing the Hinge Covers](#)).
14. Replace the bottom of the base assembly (see [Replacing the Bottom of the Base Assembly](#)).
15. Replace the modular drive (see [Replacing the Modular Drive](#)).
16. Replace the hard drive (see [Replacing the Hard Drive](#)).
17. Follow the procedure [After Working on Your Computer](#).

---

[Back to Contents Page](#)



## SD Card Reader

### Dell Precision™ Service Manual

- [Removing the SD Card Reader](#)
- [Replacing the SD Card Reader](#)

---

## Removing the SD Card Reader

**⚠ CAUTION:** Before you begin any of the procedures in this section, follow the safety instructions that shipped with your computer.

1. Follow the procedures in [Before Working on Your Computer](#).
2. Remove the hard drive (see [Removing the Hard Drive](#)).
3. Remove the modular drive (see [Removing the Modular Drive](#)).
4. Remove the bottom of the base assembly (see [Removing the Bottom of the Base Assembly](#)).
5. Remove the display assembly (see [Removing the Display Assembly](#)).
6. Remove the keyboard (see [Removing the Keyboard](#)).
7. Remove the palm rest assembly ([Removing the Palm Rest Assembly](#)).
8. If a card is in the SD card reader, remove the card.
9. Disconnect the SD card reader cable from the system board.
10. Remove the two M2.5 x 3-mm screws that secure the SD card reader.
11. Remove the SD card reader assembly from the base assembly.

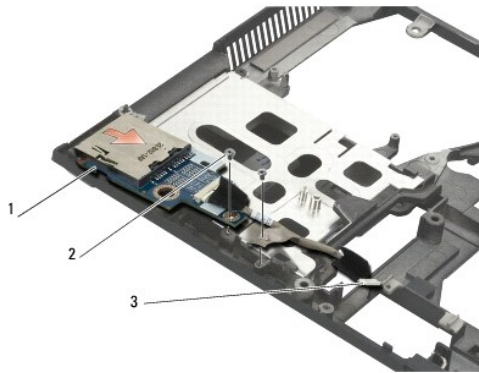

1	SD card reader assembly	2	M2 x 3-mm screw (2)
3	SD card reader cable connector		

---

## Replacing the SD Card Reader

**⚠ CAUTION:** Before you begin any of the procedures in this section, follow the safety instructions that shipped with your computer.

1. Position the SD card reader in the base assembly.
2. Replace the two M2.5 x 3-mm screws to secure the SD card reader.

3. Connect the SD card reader cable to the system board.
  4. Replace the palm rest assembly ([Replacing the Palm Rest Assembly](#)).
  5. Replace the keyboard (see [Replacing the Keyboard](#)).
  6. Replace the display assembly (see [Replacing the Display Assembly](#)).
  7. Replace the modular drive (see [Replacing the Modular Drive](#)).
  8. Replace the hard drive (see [Replacing the Hard Drive](#)).
  9. Replace the bottom of the base assembly (see [Replacing the Bottom of the Base Assembly](#)).
  10. Follow the procedure [After Working on Your Computer](#).
- 

[Back to Contents Page](#)

## Right Speaker Grill and Fingerprint Reader

### Dell Precision™ Service Manual

- [Removing the Right Speaker Grill and Fingerprint Reader](#)
- [Replacing the Right Speaker Grill and Fingerprint Reader](#)

---

## Removing the Right Speaker Grill and Fingerprint Reader

**⚠ CAUTION:** Before working inside your computer, read the safety information that shipped with your computer. For additional safety best practices information, see the Regulatory Compliance Homepage on [www.dell.com](http://www.dell.com) at: [www.dell.com/regulatory\\_compliance](http://www.dell.com/regulatory_compliance).

**🔧 NOTE:** If you do not have a fingerprint reader, ignore steps to remove or install one.

1. Follow the procedures in [Before Working on Your Computer](#).
2. Remove the hard drive (see [Removing the Hard Drive](#)).
3. Remove the modular drive (see [Removing the Modular Drive](#)).
4. Remove the LED cover (see [Removing the LED Cover](#)).
5. Remove the keyboard (see [Removing the Keyboard](#)).
6. Remove the bottom of the base assembly (see [Removing the Bottom of the Base Assembly](#)).
7. Loosen the two captured screws (indicated by an S stenciled on the base plate).



1	M2.5 x 5-mm screw (2)		
---	-----------------------	--	--

8. Remove the fingerprint reader cable.
9. Remove the plastic speaker/fingerprint reader grill.

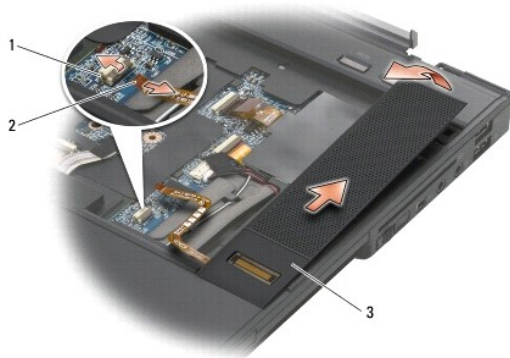

1	fingerprint reader cable connector	2	fingerprint reader cable
3	speaker/fingerprint reader grill		

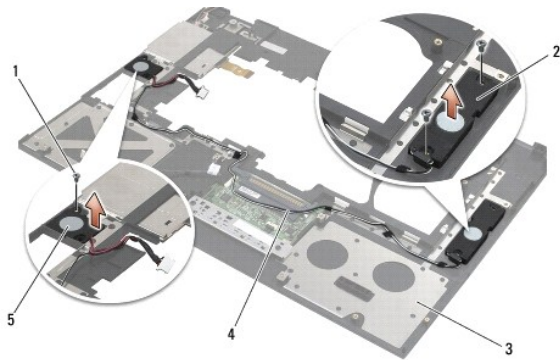

1	screw (3)	2	left speaker
3	underside of palm rest	4	speaker cables
5	right speaker		

---

## Replacing the Right Speaker Grill and Fingerprint Reader

**⚠ CAUTION:** Before working inside your computer, read the safety information that shipped with your computer. For additional safety best practices information, see the Regulatory Compliance Homepage on [www.dell.com](http://www.dell.com) at: [www.dell.com/regulatory\\_compliance](http://www.dell.com/regulatory_compliance).

**➡ NOTICE:** If you are installing a new fingerprint reader/speaker grill assembly, remove the backing paper from the bottom of the cable.

Hard drives are extremely fragile. Exercise care when handling the hard drive.

1. Connect the fingerprint reader cable. Press along the cable to seal the cable into the palm rest.
2. Snap the speaker/fingerprint reader grill into place
3. Turn the computer upside down, and tighten the two M2.5 x 5-mm captive screws.
4. Replace the bottom of the base assembly (see [Replacing the Bottom of the Base Assembly](#)).
5. Replace the keyboard (see [Replacing the Keyboard](#)).
6. Replace the LED cover (see [Replacing the LED Cover](#)).
7. Replace the modular drive (see [Replacing the Modular Drive](#)).
8. Replace the hard drive (see [Replacing the Hard Drive](#)).
9. Follow the procedure [After Working on Your Computer](#).

---

[Back to Contents Page](#)

[Back to Contents Page](#)

## System Board Assembly

Dell Precision™ Service Manual

- [Removing the System Board Assembly](#)
- [Replacing the System Board Assembly](#)

The system board's BIOS chip contains the Service Tag, which is also visible on a barcode label on the bottom of the computer. The replacement kit for the system board includes media that provides a utility for transferring the Service Tag to the replacement system board.

---

### Removing the System Board Assembly

**⚠ CAUTION:** Before working inside your computer, read the safety information that shipped with your computer. For additional safety best practices information, see the Regulatory Compliance Homepage on [www.dell.com](http://www.dell.com) at: [www.dell.com/regulatory\\_compliance](http://www.dell.com/regulatory_compliance).

1. Follow the instructions in [Before Working on Your Computer](#).
2. Close the display and turn the computer over.
3. Remove the battery (see [Removing the Battery](#)).
4. Remove the hard drive (see [Removing the Hard Drive](#)).
5. Remove the modular drive (see [Removing the Modular Drive](#)).
6. Remove the bottom of the base assembly (see [Removing the Bottom of the Base Assembly](#)).
7. Remove the card in the WWAN/FCM slot, if present (see [Removing a WWAN Card](#)).
8. Remove the card in the WLAN/WiMax slot, if present (see [Removing a WLAN Card](#)).
9. Remove the hinge covers (see [Removing the Hinge Covers](#)).
10. Remove the card in the WPAN/UWB/FCM slot, if present (see [Removing a WPAN/UWB Card](#)).
11. Remove the memory modules (see [Removing a Memory Module](#)).
12. Remove the fan (see [Removing the Fan](#)).
13. Remove the processor heat sink (see [Removing the Processor Heat Sink](#)).
14. Remove the processor (see [Removing the Processor Module](#)).
15. Remove the discrete graphics heat sink (see [Removing the Discrete Graphics Heat Sink](#)).
16. Disconnect the coin-cell battery from the system board (see [Removing the Coin-Cell Battery](#)).
17. Disconnect the DC power cable from the system board.
18. Remove the display assembly (see [Removing the Display Assembly](#)).
19. Remove the palm rest assembly (see [Removing the Palm Rest Assembly](#)).
20. Disconnect the SD card cable from the system board.
21. Disconnect the Express card cable from the system board.
22. Disconnect the I/O board cable from the system board.
23. Remove the two M2 x 3-mm screws securing the PC card cage.
24. Uncouple the PC card cage from its mounting bracket by lifting the latch tab with a small plastic scribe.

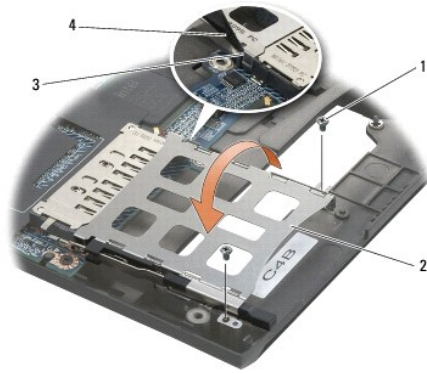

1	M2 x 3-mm screw (2)	2	PC card cage
3	latch tab	4	plastic scribe

25. Remove five M2.5 x 5-mm screws labeled with white arrows from the system board.
26. Pull out on the top, left corner of the base assembly to release the DC, USB, and serial connectors.
27. Lift the top, right edge of the system board to disconnect the it from the I/O board, then carefully lift the system board out of the computer.

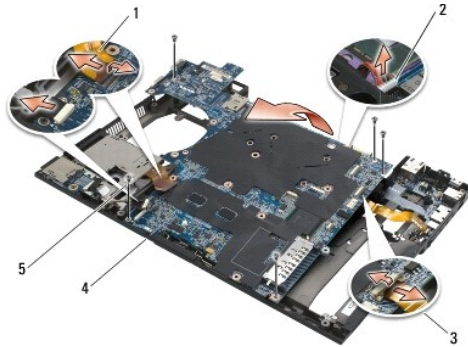

1	SD cable and Express card cage cable connectors	2	DC power cable connector
3	I/O board cable connector	4	system board
5	M2.5 x 5-mm system board screws (5)		



## Replacing the System Board Assembly

**CAUTION:** Before working inside your computer, read the safety information that shipped with your computer. For additional safety best practices information, see the Regulatory Compliance Homepage on [www.dell.com](http://www.dell.com) at: [www.dell.com/regulatory\\_compliance](http://www.dell.com/regulatory_compliance).

**NOTICE:** Ensure that any loose cables do not get caught beneath the system board.

Replace the system board in the opposite order of removal.

1. Insert the bottom edge of the system board into the base of the computer, ensuring the system board is under the metal latch mechanism.
2. Place the top, left corner of the system board into the base, then connect the top right of the system board to the I/O board connector.
3. Position the system board into the base, ensure that the DC, USB, and serial connectors fit into the base assembly.
4. Replace the five M2.5 x 4-mm screws to secure the system board.
5. Connect the I/O board cable to the system board.
6. Replace the PC card cage by gently pushing the inward end of the cage down over its mounting bracket.

7. Replace the two M2 x 3-mm screws securing the PC card cage.
8. Replace the Express card cage (see [Replacing the Express Card Cage](#)).
9. Connect the Express card cable to the system board.
10. Replace the SD card reader assembly (see [Replacing the SD Card Reader](#)).
11. Connect the SD card cable to the system board.
12. Replace the palm rest assembly (see [Replacing the Palm Rest Assembly](#)).
13. Replace the keyboard (see [Replacing the Keyboard](#)).
14. Replace the LED cover (see [Replacing the LED Cover](#)).
15. Replace the display assembly (see [Display Assembly](#)).
16. Replace the hinge covers (see [Replacing the Hinge Covers](#)).
17. Replace the modem (see [Replacing the Modem](#)).
18. Connect the DC power cable to the system board.
19. Connect the coin-cell battery cable to the system board (see [Replacing the Coin-Cell Battery](#)).
20. Replace the discrete graphics heat sink (see [Replacing the Discrete Graphics Heat Sink](#)).
21. Replace the processor (see [Replacing the Processor Module](#)).
22. Replace the processor heat sink (see [Replacing the Processor Heat Sink](#)).
23. Replace the fan (see [Replacing the Fan](#)).
24. Replace the memory modules (see [Replacing a Memory Module](#)).
25. Replace the WPAN/UWB/FCM card if one was installed (see [Replacing a WPAN/UWB Card](#)).
26. Replace the WLAN/WiMax card if one was installed (see [Replacing a WLAN Card](#)).
27. Replace the WWAN/FCM card if one was installed (see [Replacing a WWAN Card](#)).
28. Replace the bottom of the base assembly (see [Replacing the Bottom of the Base Assembly](#)).
29. Replace the modular drive (see [Removing the Modular Drive](#)).
30. Replace the hard drive (see [Removing the Hard Drive](#)).
-  **NOTICE:** Before turning on the computer, replace all screws and ensure that no stray screws remain inside the computer. Failure to do so may result in damage to the computer.
31. Follow the procedure [After Working on Your Computer](#).
32. Turn on the computer.
-  **NOTE:** If you use a BIOS update program CD to flash the BIOS, press <F12> before inserting the CD in order to set the computer to boot from the CD for one time only. Otherwise, you must enter the system setup program to change the default boot order.
33. Update the BIOS (see [Flashing the BIOS](#) for more information).
34. Enter the system setup program to update the BIOS on the new system board with the computer Service Tag. For information on the system setup program, see the *Dell™ Technology Guide* on your computer or at [support.dell.com](http://support.dell.com).

[Back to Contents Page](#)

## Service Manual



**NOTE:** A NOTE indicates important information that helps you make better use of your computer.



**NOTICE:** A NOTICE indicates either potential damage to hardware or loss of data and tells you how to avoid the problem.



**CAUTION:** A CAUTION indicates potential for property damage, personal injury, or death.

If you purchased a DELL™ n Series computer, any references in this document to Microsoft® Windows® operating systems are not applicable.

Information in this document is subject to change without notice.  
© 2008 Dell Inc. All rights reserved.

Reproduction in any manner whatsoever without the written permission of Dell Inc. is strictly forbidden.

Trademarks used in this text: *Dell*, the *DELL* logo, and *Dell Precision* are trademarks of Dell Inc.; *Microsoft*, *Windows*, *Windows Vista*, and the *Windows Start button logo* are either trademarks or registered trademarks of Microsoft Corporation in the United States and/or other countries.

Other trademarks and trade names may be used in this document to refer to either the entities claiming the marks and names or their products. Dell Inc. disclaims any proprietary interest in trademarks and trade names other than its own.

June 2008 Rev. A00

---

[Back to Contents Page](#)



## Troubleshooting

### Dell Precision™ Service Manual

- [Troubleshooting Tools](#)
- [Solving Problems](#)
- [Dell™ Technical Update Service](#)

## Troubleshooting Tools

### Diagnostic Lights

**⚠ CAUTION:** Before you begin any of the procedures in this section, follow the safety instructions that shipped with your computer.

Your computer has three keyboard status lights located above the keyboard. During normal operation, the keyboard status lights display the current status (*on* or *off*) of the Num Lock, Caps Lock, and Scroll Lock features. If the computer starts without error, the lights flash, and then turn off. If the computer malfunctions, however, you can use the status of the lights to help identify the problem.

**🔍 NOTE:** After the computer completes POST, the Num Lock light may remain on, depending on your BIOS settings. For more information on using the system setup program, see the *Dell™ Technology Guide* on your computer or at [support.dell.com](http://support.dell.com).

### Diagnostic Light Codes During POST

To troubleshoot a problem with your computer, read the sequence of the keyboard status lights in order from left to right (Num Lock, Caps Lock, and then Scroll Lock). If the computer malfunctions the individual lights display a status of either *On* ●, *Off* ○, or *Flashing* ✱.

Light Pattern	Problem Description	Suggested Resolution
● ✱ ✱	No memory modules are detected.	<ul style="list-style-type: none"><li>1 If two or more memory modules are installed, remove the modules (see <a href="#">Removing a Memory Module</a>), then reinstall one module (see <a href="#">Replacing a Memory Module</a>) and restart the computer. If the computer starts normally, continue to install additional memory modules (one at a time) until you have identified a faulty module or reinstalled all modules without error.</li><li>1 If available, install working memory of the same type into your computer (see <a href="#">Memory</a>).</li><li>1 If the problem persists, contact Dell Support.</li></ul>
● ✱ ○	Memory modules are detected, but a memory failure has occurred.	<ul style="list-style-type: none"><li>1 If two or more memory modules are installed, remove the modules (see <a href="#">Removing a Memory Module</a>), then reinstall one module (see <a href="#">Replacing a Memory Module</a>) and restart the computer. If the computer starts normally, continue to install additional memory modules (one at a time) until you have identified a faulty module or reinstalled all modules without error.</li><li>1 If available, install working memory of the same type into your computer (see <a href="#">Memory</a>).</li><li>1 If the problem persists, contact Dell Support.</li></ul>
✱ ○ ○	A possible processor failure has occurred.	<ul style="list-style-type: none"><li>1 Reseat the processor (see <a href="#">Removing the Processor Module</a>).</li><li>1 If the problem persists, contact Dell Support.</li></ul>
✱ ✱ ○	A possible graphics card/video failure has occurred.	<ul style="list-style-type: none"><li>1 Reseat any installed graphics cards.</li><li>1 If available, install a working graphics card into your computer.</li><li>1 If the problem persists, contact Dell Support.</li></ul>
✱ ○ ✱	A possible display failure has occurred.	<ul style="list-style-type: none"><li>1 Reseat the display cable (see <a href="#">Removing the Display Assembly</a>).</li><li>1 If the problem persists, contact Dell Support.</li></ul>
✱ ○ ✱	SPD data indicates all SODIMMs are unusable.	<ul style="list-style-type: none"><li>1 Remove the unusable memory module (see <a href="#">Removing a Memory Module</a>).</li><li>1 Replace with a usable memory module (see <a href="#">Replacing a Memory Module</a>).</li></ul>

### Hardware Troubleshooter

If a device is either not detected during the operating system setup or is detected, but incorrectly configured, you can use the Hardware Troubleshooter to resolve the incompatibility.

*Windows XP:*

1. Click **Start**→ **Help and Support**.

2. Type `hardware troubleshooter` in the search field and press <Enter> to start the search.
3. In the **Fix a Problem** section, click **Hardware Troubleshooter**.
4. In the **Hardware Troubleshooter** list, select the option that best describes the problem, and click **Next** to follow the remaining troubleshooting steps.

Windows Vista®:

1. Click the Windows Vista start button , and click **Help and Support**.
2. Type `hardware troubleshooter` in the search field and press <Enter> to start the search.
3. In the search results, select the option that best describes the problem and follow the remaining troubleshooting steps.

## Dell Diagnostics

 **CAUTION:** Before you begin any of the procedures in this section, follow the safety instructions that shipped with your computer.

### When to Use the Dell Diagnostics

If you experience a problem with your computer, perform the checks in [Solving Problems](#), and then run the Dell Diagnostics before contacting Dell for assistance.

Start the Dell Diagnostics from your hard drive or from the *Drivers and Utilities* media provided with your computer.

 **NOTE:** The *Drivers and Utilities* media is optional and may not ship with your computer.

 **NOTE:** The Dell Diagnostics only operate on Dell computers.

### Starting the Dell Diagnostics From Your Hard Drive

Before running the Dell Diagnostics, enter system setup to review your computer's configuration information, and ensure that the device you want to test is displayed in system setup and is active. For more information on using the system setup program, see the *Dell™ Technology Guide* on your computer or at [support.dell.com](http://support.dell.com).

The Dell Diagnostics is located on a separate diagnostic utility partition on your hard drive.

 **NOTE:** If the computer is connected to a docking device (docked), undock it. See the documentation that came with your docking device for instructions.

 **NOTE:** If your computer does not display a screen image, contact Dell Support.

1. Ensure that the computer is connected to an electrical outlet that is known to be working properly.
2. Press and hold the <Fn> key or the mute button then turn on your computer.

 **NOTE:** Alternatively, you can select **Diagnostics** from the one-time boot menu at startup to boot to the diagnostic utility partition and run the Dell Diagnostics.

The computer runs the Pre-boot System Assessment (PSA), a series of initial tests of your system board, keyboard, display, memory, hard drive, etc.

1. During the assessment, answer any questions that appear.
1. If failures are detected during the Pre-boot System Assessment, write down the error code(s) and contact Dell Support.
1. If the Pre-boot System Assessment completes successfully, the following message appears: "Booting Dell Diagnostic Utility Partition. Press any key to continue."

 **NOTE:** If you see a message stating that no diagnostics utility partition has been found, run the Dell Diagnostics from your *Drivers and Utilities* media (see [Starting the Dell Diagnostics From the Drivers and Utilities Media](#)).

3. Press any key to start the Dell Diagnostics from the diagnostics utility partition on your hard drive.
  4. Press <Tab> to select **Test System** and then press <Enter>.
-  **NOTE:** It is recommended that you select **Test System** to run a complete test on your computer. Selecting **Test Memory** initiates the extended memory test, which can take up to thirty minutes or more to complete. When the test completes, record the test results and then press any key to return to the previous menu.
5. At the Dell Diagnostics Main Menu, left-click with the touch pad/mouse, or press <Tab> and then <Enter>, to select the test you want to run (see [Dell](#)

[Diagnostics Main Menu](#)).

 **NOTE:** Write down any error codes and problem descriptions exactly as they appear and follow the instructions on the screen.

6. After all tests have completed, close the test window to return to the Dell Diagnostics Main Menu.
7. Close the Main Menu window to exit the Dell Diagnostics and restart the computer.

 **NOTE:** If you see a message stating that no diagnostics utility partition has been found, run the Dell Diagnostics from your *Drivers and Utilities* media (see [Starting the Dell Diagnostics From the Drivers and Utilities Media](#)).

## Starting the Dell Diagnostics From the Drivers and Utilities Media

Before running the Dell Diagnostics, enter system setup to review your computer's configuration information, and ensure that the device you want to test is displayed in system setup and is active. For more information on using the system setup program, see the *Dell™ Technology Guide* on your computer or at [support.dell.com](http://support.dell.com).

1. Insert the *Drivers and Utilities* media into the optical drive.
2. Restart your computer.
3. When the DELL logo appears, press <F12> immediately.

 **NOTE:** Keyboard failure may result when a key is held down for extended periods of time. To avoid possible keyboard failure, press and release <F12> in even intervals to open the Boot Device Menu.

If you wait too long and the operating system logo appears, continue to wait until you see the Microsoft Windows desktop, then shut down your computer and try again.

4. When the boot device list appears, use the up- or down- arrow keys to highlight **CD/DVD/CD-RW Drive** then press <Enter>.

 **NOTE:** Using the one-time boot menu changes the boot sequence for the current boot only. Upon restart, the computer boots according to the boot sequence specified in system setup.

5. Press any key to confirm that you want to start from the CD/DVD.

If you wait too long and the operating system logo appears, continue to wait until you see the Microsoft Windows desktop, then shut down your computer and try again.

6. Type 1 to **Run the 32 Bit Dell Diagnostics**.
7. At the **Dell Diagnostics Menu**, type 1 to select **Dell 32-bit Diagnostics for Resource CD (graphical user interface)**.
8. Press <Tab> to select **Test System** and then press <Enter>.

 **NOTE:** It is recommended that you select **Test System** to run a complete test on your computer. Selecting **Test Memory** initiates the extended memory test, which can take up to thirty minutes or more to complete. When the test completes, record the test results and then press any key to return to the previous menu.

9. At the Dell Diagnostics Main Menu, left-click with the mouse, or press <Tab> and then <Enter>, to select the test you want to run (see [Dell Diagnostics Main Menu](#)).

 **NOTE:** Write down any error codes and problem descriptions exactly as they appear and follow the instructions on the screen.

10. After all tests have completed, close the test window to return to the Dell Diagnostics Main Menu.
11. Close the Main Menu window to exit the Dell Diagnostics and restart the computer.
12. Remove the *Drivers and Utilities* media from the optical drive.

## Dell Diagnostics Main Menu

After the Dell Diagnostics loads the following menu appears:

Option	Function
Test Memory	Run the stand-alone memory test

Test System	Run system diagnostics
Exit	Exit the diagnostics

Press <Tab> to select the test you want to run and then press <Enter>.

 **NOTE:** It is recommended that you select **Test System** to run a complete test on your computer. Selecting **Test Memory** initiates the extended memory test, which can take up to thirty minutes or more to complete. When the test completes, record the test results and then press any key to return to this menu.

After **Test System** is selected, the following menu appears:

Option	Function
Express Test	Performs a quick test of devices in the system. This typically can take 10 to 20 minutes.  <b>NOTE:</b> The Express Test requires no interaction on your part. Run Express Test first to increase the possibility of tracing a problem quickly.
Extended Test	Performs a thorough check of devices in the system. This typically can take 1 hour or more.  <b>NOTE:</b> The Extended Test periodically requires your input to answer specific questions.
Custom Test	Use to test a specific device or customize the tests to be run.
Symptom Tree	This option allows you to select tests based on a symptom of the problem you are having. This option lists the most common symptoms.

 **NOTE:** It is recommended that you select **Extended Test** to perform a more thorough check of devices in the computer.

For any problem encountered during a test, a message appears with an error code and a description of the problem. Write down the error code and problem description exactly as it appears and follow the instructions on the screen. If you cannot resolve the problem, contact Dell Support.

 **NOTE:** When contacting Dell Support, have your Service Tag ready. The Service Tag for your computer is located at the top of each test screen.

The following tabs provide additional information for tests run from the Custom Test or Symptom Tree option:

Tab	Function
Results	Displays the results of the test and any error conditions encountered.
Errors	Displays error conditions encountered, error codes, and the problem description.
Help	Describes the test and any requirements for running the test.
Configuration	Displays the hardware configuration for the selected device.  The Dell Diagnostics obtains configuration information for all devices from System Setup, memory, and various internal tests, and displays the information in the device list in the left pane of the screen.  <b>NOTE:</b> The device list may not display the names of all components installed on your computer or all devices attached to your computer.
Parameters	Allows you to customize the test, if applicable, by changing the test settings.

## Error Messages

 **CAUTION:** Before you begin any of the procedures in this section, follow the safety instructions that shipped with your computer.

If the error message is not listed, see the documentation for the operating system or the program that was running when the message appeared.

**A filename cannot contain any of the following characters:**

\ / : \* ? " < > | — Do not use these characters in filenames.

**A required .DLL file was not found** — The program that you are trying to open is missing an essential file. To remove and then reinstall the program:

Windows XP:

1. Click **Start**→ **Control Panel**→ **Add or Remove Programs**→ **Programs and Features**.
2. Select the program you want to remove.
3. Click **Uninstall**.
4. See the program documentation for installation instructions.

Windows Vista:

1. Click **Start**  → **Control Panel** → **Programs** → **Programs and Features**.
2. Select the program you want to remove.
3. Click **Uninstall**.
4. See the program documentation for installation instructions.

**drive letter :\\ is not accessible. The device is not ready** — The drive cannot read the disk. Insert a disk into the drive and try again.

**Insert bootable media** — Insert a bootable floppy disk, CD, or DVD.

**Non-system disk error** — Remove the floppy disk from the floppy drive and restart your computer.

**Not enough memory or resources. Close some programs and try again** — Close all windows and open the program that you want to use. In some cases, you may have to restart your computer to restore computer resources. If so, run the program that you want to use first.

**Operating system not found** — Contact Dell Support.

---

## Solving Problems

Follow these tips when troubleshooting your computer:

- 1 If you added or removed a part before the problem started, review the installation procedures and ensure that the part is correctly installed.
- 1 If a peripheral device does not work, ensure that the device is properly connected.
- 1 If an error message appears on the screen, write down the exact message. This message may help support personnel diagnose and fix the problem(s).
- 1 If an error message occurs in a program, see the program's documentation.

 **NOTE:** The procedures in this document were written for the Windows default view, so they may not apply if you set your Dell computer to the Windows Classic view.

## Battery Problems

 **CAUTION:** There is a danger of a new battery exploding if it is incorrectly installed. Replace the battery only with the same or equivalent type recommended by the manufacturer. Discard used batteries according to the manufacturer's instructions.

 **CAUTION:** Before you begin any of the procedures in this section, follow the safety instructions that shipped with your computer.

## Drive Problems

 **CAUTION:** Before you begin any of the procedures in this section, follow the safety instructions that shipped with your computer.

**Ensure that Microsoft® Windows® Recognizes the drive** —

Windows XP:

- 1 Click **Start** and click **My Computer**.

Windows Vista:

- 1 Click **Start**  and click **Computer**.

If the drive is not listed, perform a full scan with your antivirus software to check for and remove viruses. Viruses can sometimes prevent Windows from recognizing the drive.

**Test the drive** —

- 1 Insert another disc to eliminate the possibility that the original drive is defective.

- 1 Insert a bootable floppy disk and restart the computer.

#### Clean the drive or disk —

For information on cleaning your computer, see the *Dell™ Technology Guide* on your computer or at [support.dell.com](http://support.dell.com).

#### Check the cable connections

#### Run the Hardware Troubleshooter —

See [Hardware Troubleshooter](#).

#### Run the Dell Diagnostics —

See [Dell Diagnostics](#).

## Optical drive problems

 **NOTE:** High-speed optical drive vibration is normal and may cause noise, which does not indicate a defect in the drive or the media.

 **NOTE:** Because of different regions worldwide and different disc formats, not all DVD titles work in all DVD drives.

#### Adjust the Windows volume control —

- 1 Click the speaker icon in the lower-right corner of your screen.
- 1 Ensure that the volume is turned up by clicking the slider and dragging it up.
- 1 Ensure that the sound is not muted by clicking any boxes that are checked.

#### Check the speakers and subwoofer —

See [Sound and Speaker Problems](#).

## Problems writing to an optical drive

#### Close other programs —

The optical drive must receive a steady stream of data during the writing process. If the stream is interrupted, an error occurs. Try closing all programs before you write to the optical.

#### Turn off standby mode in Windows before writing to a disc —

For information about setting power options, see the *Dell™ Technology Guide* on your computer or at [support.dell.com](http://support.dell.com). You can also search for the keyword *standby* in Windows Help and Support for information on power management modes.

## Hard drive problems

#### Run Check Disk —

*Windows XP:*

1. Click **Start** and click **My Computer**.
2. Right-click **Local Disk C:**.
3. Click **Properties**→**Tools**→**Check Now**.
4. Click **Scan for and attempt recovery of bad sectors and click Start**.

*Windows Vista:*

1. Click **Start**  and click **Computer**.
2. Right-click **Local Disk C:**.
3. Click **Properties**→**Tools**→**Check Now**.

The **User Account Control** window may appear. If you are an administrator on the computer, click **Continue**; otherwise, contact your administrator to continue the desired action.

4. Follow the instructions on the screen.

## IEEE 1394 Device Problems

 **CAUTION:** Before you begin any of the procedures in this section, follow the safety instructions that shipped with your computer.

 **NOTE:** Your computer supports only IEEE 1394a standard.

**Ensure that the cable for the IEEE 1394 device is properly inserted into the device and into the connector on the computer**

**Ensure that the IEEE 1394 device is enabled in system setup** — For more information on using the system setup program, see the *Dell™ Technology Guide* on your computer or at [support.dell.com](http://support.dell.com).

**Ensure that the IEEE 1394 device is recognized by Windows** —

*Windows XP:*

1. Click **Start** and click **Control Panel**.
2. Under **Pick a Category**, click **Performance and Maintenance** → **System** → **System Properties** → **Hardware** → **Device Manager**.

*Windows Vista:*

1. Click **Start**  → **Control Panel** → **Hardware and Sound**.
2. Click **Device Manager**.

If your IEEE 1394 device is listed, Windows recognizes the device.

**If you have problems with a Dell IEEE 1394 device** —

Contact Dell Support.

**If you have problems with an IEEE 1394 device not provided by Dell** — Contact the IEEE 1394 device manufacturer.

## Lockups and Software Problems

 **CAUTION:** Before you begin any of the procedures in this section, follow the safety instructions that shipped with your computer.

### The computer does not start up

**Check the diagnostic lights** —

See [Power Problems](#).

**Ensure that the power cable is firmly connected to the computer and to the electrical outlet**

### The computer stops responding

 **NOTICE:** You may lose data if you are unable to perform an operating system shutdown.

**Turn the computer off** — If you are unable to get a response by pressing a key on your keyboard or moving your mouse, press and hold the power button for at least 8 to 10 seconds (until the computer turns off), and then restart your computer.

### A program stops responding

**End the program** —

1. Press <Ctrl><Shift><Esc> simultaneously to access the Task Manager.
2. Click the **Applications** tab.
3. Click to select the program that is no longer responding.
4. Click **End Task**.

## A program crashes repeatedly

 **NOTE:** Most software includes installation instructions in its documentation or on a floppy disk, CD, or DVD.

### Check the software documentation —

If necessary, uninstall and then reinstall the program.

## A program is designed for an earlier Windows operating system

### Run the Program Compatibility Wizard —

*Windows XP:*

The Program Compatibility Wizard configures a program so that it runs in an environment similar to non-XP operating system environments.

1. Click **Start** → **All Programs** → **Accessories** → **Program Compatibility Wizard** → **Next**.
2. Follow the instructions on the screen.

*Windows Vista:*

The Program Compatibility Wizard configures a program so that it runs in an environment similar to non-Windows Vista operating system environments.

1. Click **Start**  → **Control Panel** → **Programs** → **Use an older program with this version of Windows**.
2. In the welcome screen, click **Next**.
3. Follow the instructions on the screen.

## A solid blue screen appears

### Turn the computer off —

If you are unable to get a response by pressing a key on your keyboard or moving your mouse, press and hold the power button for at least 8 to 10 seconds (until the computer turns off), and then restart your computer.

## Other software problems

### Check the software documentation or contact the software manufacturer for troubleshooting information —

- 1. Ensure that the program is compatible with the operating system installed on your computer.
- 1. Ensure that your computer meets the minimum hardware requirements needed to run the software. See the software documentation for information.
- 1. Ensure that the program is installed and configured properly.
- 1. Verify that the device drivers do not conflict with the program.
- 1. If necessary, uninstall and then reinstall the program.

### Back up your files immediately

Use a virus-scanning program to check the hard drive, floppy disks, CDs, or DVDs

Save and close any open files or programs and shut down your computer through the Start menu

## Memory Problems

 **CAUTION:** Before you begin any of the procedures in this section, follow the safety instructions that shipped with your computer.

### If you receive an insufficient memory message —



- 1 Save and close any open files and exit any open programs you are not using to see if that resolves the problem.
- 1 See the software documentation for minimum memory requirements. If necessary, install additional memory (see [Replacing a Memory Module](#)).
- 1 Reseat the memory modules (see [Memory](#)) to ensure that your computer is successfully communicating with the memory.
- 1 Run the Dell Diagnostics (see [Dell Diagnostics](#)).

#### If you experience other memory problems —

- 1 Reseat the memory modules (see [Memory](#)) to ensure that your computer is successfully communicating with the memory.
- 1 Ensure that you are following the memory installation guidelines (see [Replacing a Memory Module](#)).
- 1 Ensure that the memory you are using is supported by your computer. For more information about the type of memory supported by your computer, see the *Setup and Quick Reference Guide* for your computer at [support.dell.com](#).
- 1 Run the Dell Diagnostics (see [Dell Diagnostics](#)).

## Power Problems

 **CAUTION:** Before you begin any of the procedures in this section, follow the safety instructions that shipped with your computer.

If the power light is green and the computer is not responding — See [Diagnostic Lights](#).

If the power light is off — The computer is either turned off or is not receiving power.

- 1 Reseat the power cable in the power connector on the back of the computer and the electrical outlet.
- 1 Bypass power strips, power extension cables, and other power protection devices to verify that the computer turns on properly.
- 1 Ensure that any power strips being used are plugged into an electrical outlet and are turned on.
- 1 Ensure that the electrical outlet is working by testing it with another device, such as a lamp.

Eliminate interference — Some possible causes of interference are:

- 1 Power, keyboard, and mouse extension cables
- 1 Too many devices connected to the same power strip
- 1 Multiple power strips connected to the same electrical outlet

## Sound and Speaker Problems

 **CAUTION:** Before you begin any of the procedures in this section, follow the safety instructions that shipped with your computer.

### No sound from speakers

 **NOTE:** The volume control in MP3 and other media players may override the Windows volume setting. Always check to ensure that the volume on the media player(s) has not been turned down or off.

**Adjust the Windows volume control** — Click or double-click the speaker icon in the lower-right corner of your screen. Ensure that the volume is turned up and that the sound is not muted.

**Disconnect headphones from the headphone connector** — Sound from the speakers is automatically disabled when headphones are connected to the computer's front-panel headphone connector.

**Eliminate possible interference** — Turn off nearby fans, fluorescent lights, or halogen lamps to check for interference.

**Run the Hardware Troubleshooter** — See [Hardware Troubleshooter](#).

### No sound from headphones

**Check the headphone cable connection** — Ensure that the headphone cable is securely inserted into the headphone connector. See the *Setup and Quick Reference Guide* for your computer at [support.dell.com](#).

**Adjust the Windows volume control** — Click or double-click the speaker icon in the lower-right corner of your screen. Ensure that the volume is turned up and

that the sound is not muted.

## Video and Display Problems

 **CAUTION:** Before you begin any of the procedures in this section, follow the safety instructions that shipped with your computer.

 **NOTICE:** If your computer came with a PCI graphics card installed, removal of the card is not necessary when installing additional graphics cards; however, the card is required for troubleshooting purposes. If you remove the card, store it in a safe and secure location. For information about your graphics card, go to [support.dell.com](http://support.dell.com).

### Check the diagnostic lights —

See [Diagnostic Lights](#).

### Check the display settings —

See the *Dell™ Technology Guide* on your computer or at [support.dell.com](http://support.dell.com).

### Adjust the Windows display settings —

*Windows XP:*

1. Click **Start** → **Control Panel** → **Appearance and Themes**.
2. Click the area you want to change or click the **Display** icon.
3. Try different settings for **Color quality** and **Screen resolution**.

*Windows Vista:*

1. Click **Start**  → **Control Panel** → **Hardware and Sound** → **Personalization** → **Display Settings**.
2. Adjust **Resolution** and **Colors settings**, as needed.

## Only part of the display is readable

### Connect an external monitor —

1. Shut down your computer and connect an external monitor to the computer.
2. Turn on the computer and the monitor and adjust the monitor brightness and contrast controls.

If the external monitor works, the computer display or video controller may be defective. Contact Dell Support.

---

## Dell™ Technical Update Service

The Dell Technical Update service provides proactive e-mail notification of software and hardware updates for your computer. The service is free and can be customized for content, format, and how frequently you receive notifications.

To enroll for the Dell Technical Update service, go to [support.dell.com/technicalupdate](http://support.dell.com/technicalupdate).

---

[Back to Contents Page](#)

## WLAN Card

### Dell Precision™ Service Manual

- [Removing a WLAN Card](#)
- [Replacing a WLAN Card](#)

**⚠ CAUTION:** Before you begin any of the procedures in this section, follow the safety instructions that shipped with your computer.

Your computer supports a Wireless Local Area Network (WLAN) card. If you ordered a WLAN card with your computer, the card is already installed.

## Removing a WLAN Card

1. Follow the procedures in [Before Working on Your Computer](#).
2. Close the display and turn the computer over.
3. Remove the bottom of the base assembly (see [Removing the Bottom of the Base Assembly](#)).
4. Disconnect the antenna cables from the WLAN card.
5. Remove the M2 x 3-mm screw securing the WLAN card.

The card will pop up to a 30-degree angle to the system board.

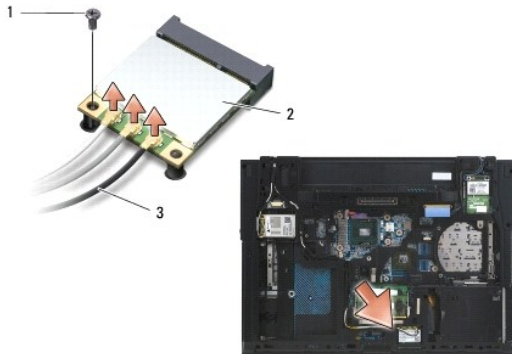

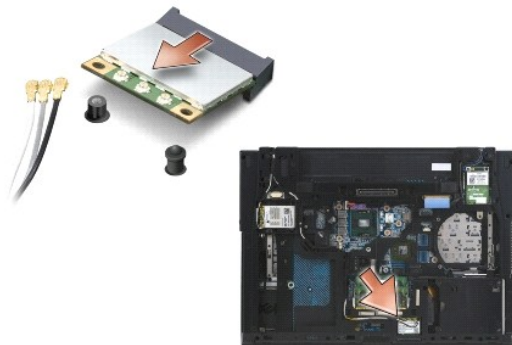

1	M2 x 3-mm screw	2	WLAN card
3	antenna cable connectors (3)		

6. Slide the WLAN card out of its connector at a 30-degree angle to the system board.



## Replacing a WLAN Card

 **NOTICE:** The connectors are keyed to ensure correct insertion. If you feel resistance, check the connectors on the card and on the system board, and realign the card.

 **NOTICE:** To avoid damage to the WLAN card, ensure the cables are not under the card when you place the card.

 **NOTE:** The card slot will be marked by a WLAN label. Do not install the WLAN card into any other card slot.

1. Slide the WLAN card into the connector at a 30-degree angle to the system board.
2. Press the card down onto the alignment post and hold in position.
3. Replace the M2x3-mm screw to secure the WLAN card.
4. Connect the appropriate antenna cables to the WLAN card you are installing:

If the WLAN card has two triangles on the label (white and black), connect the white antenna cable to the connector labeled "main" (white triangle), and connect the black antenna cable to the connector labeled "aux" (black triangle). Place the remaining gray cable in the chassis next to the card.

If the WLAN card has three triangles on the label (white, black, and gray), connect the white antenna cable to the white triangle, connect the black antenna cable to the black triangle, and connect the gray antenna cable to the gray triangle.

 **NOTE:** Ensure the antenna cables are routed through the cable channel.

5. Replace the bottom of the base assembly (see [Removing the Bottom of the Base Assembly](#)).
6. Follow the procedure [After Working on Your Computer](#).

---

[Back to Contents Page](#)

## WPAN/UWB Card

### Dell Precision™ Service Manual

- [Removing a WPAN/UWB Card](#)
- [Replacing a WPAN/UWB Card](#)

**⚠ CAUTION:** Before you begin any of the procedures in this section, follow the safety instructions that shipped with your computer.

Your computer supports a Wireless Personal Area Network (WPAN/UWB) card. If you ordered a WPAN/UWB card with your computer, the card is already installed.

---

## Removing a WPAN/UWB Card

1. Follow the procedures in [Before Working on Your Computer](#).
2. Close the display and turn the computer over.
3. Remove the bottom of the base assembly (see [Removing the Bottom of the Base Assembly](#)).
4. Remove the left hinge cover (see [Removing the Hinge Covers](#)).
5. Disconnect the blue antenna cable from the WPAN/UWB card.
6. Remove the M2 x 3-mm screw from the WPAN/UWB card. The card will pop up to a 30-degree angle to the system board.

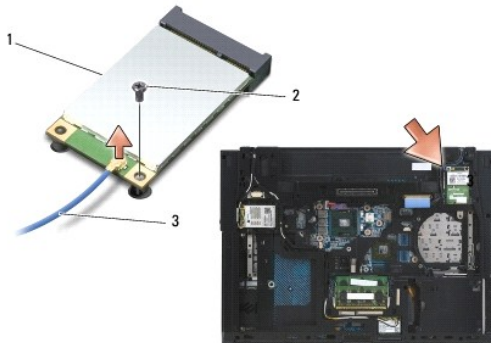

1	WPAN/UWB card	2	M2 x 3-mm screw
3	antenna cable		

7. Slide the WPAN/UWB card out of its connector.

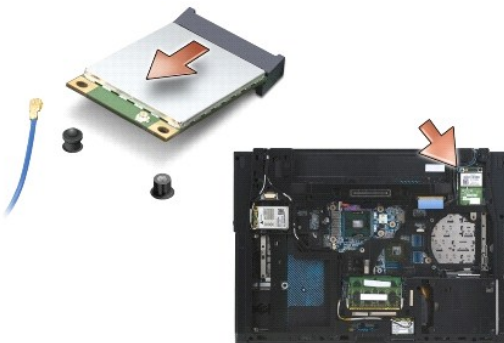

## Replacing a WPAN/UWB Card

➡ **NOTICE:** To avoid damage to the WPAN/UWB card, ensure the cables are not under the card when you replace the card.

➡ **NOTICE:** The Mini-Card slot has a WPAN/UWB/FCM label inside the slot. Do not install a WPAN (WPAN/UWB) card in any other location.

1. Slide the WPAN/UWB card into the connector at a 30-degree angle to the system board.
2. Press the card down onto the alignment post and hold in position.
3. Install the M2 x 3-mm screw to secure the WPAN/UWB card.
4. Connect the blue antenna cable to the WPAN/UWB card.
5. Install the left hinge cover (see [Replacing the Hinge Covers](#)).
6. Install the bottom of the base assembly (see [Removing the Bottom of the Base Assembly](#)).
7. Follow the procedure [After Working on Your Computer](#).

---

[Back to Contents Page](#)

## WWAN Card

### Dell Precision™ Service Manual

- [Removing a WWAN Card](#)
- [Replacing a WWAN Card](#)

**⚠ CAUTION:** Before you begin any of the procedures in this section, follow the safety instructions that shipped with your computer.

Your computer supports a Wireless Wide Area Network (WWAN) card. If you ordered a WWAN card with your computer, the card is already installed.

---

## Removing a WWAN Card

1. Follow the procedures in [Before Working on Your Computer](#).
2. Close the display and turn the computer over.
3. Remove the bottom of the base assembly (see [Removing the Bottom of the Base Assembly](#)).
4. Disconnect the antenna cables from the WWAN card.
5. Remove the M2 x 3-mm screw that secures the WWAN card. The card will pop up to a 30-degree angle to the system board.

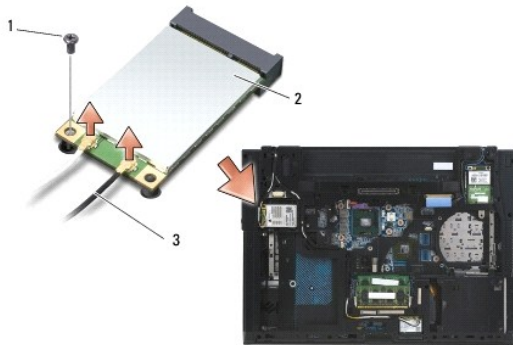

1	M2 x 3-mm screw	2	WWAN card
3	antenna cables (2)		

6. Slide the WWAN card out of its connector.

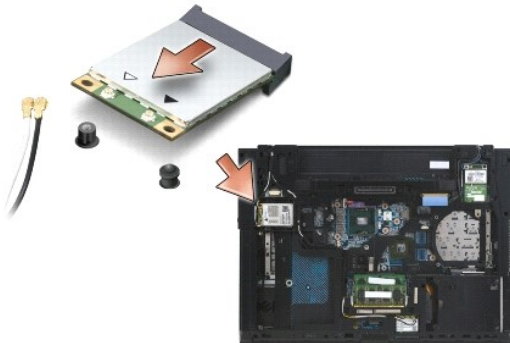

---

## Replacing a WWAN Card

➡ **NOTICE:** The connectors are keyed to ensure correct insertion. If you feel resistance, check the connectors on the card and on the system board, and realign the card.

➡ **NOTICE:** To avoid damage to the WWAN card, ensure the cables are not under the card when you click the card into place.

➡ **NOTICE:** Install the WWAN card into the compartment shown in the above photograph. Do not install it in any other location.

1. Slide the WWAN card into the connector at a 30-degree angle to the system board.
2. Press the card down onto the alignment post and hold in position.
3. Replace the M2 x 3-mm screw to secure the card.
4. Connect the white antenna cable to the connector labeled "main" (white triangle), and connect the black antenna cable to the connector labeled "aux" (black triangle).
5. Replace the bottom of the base assembly (see [Removing the Bottom of the Base Assembly](#)).
6. Follow the procedure [After Working on Your Computer](#).

---

[Back to Contents Page](#)